

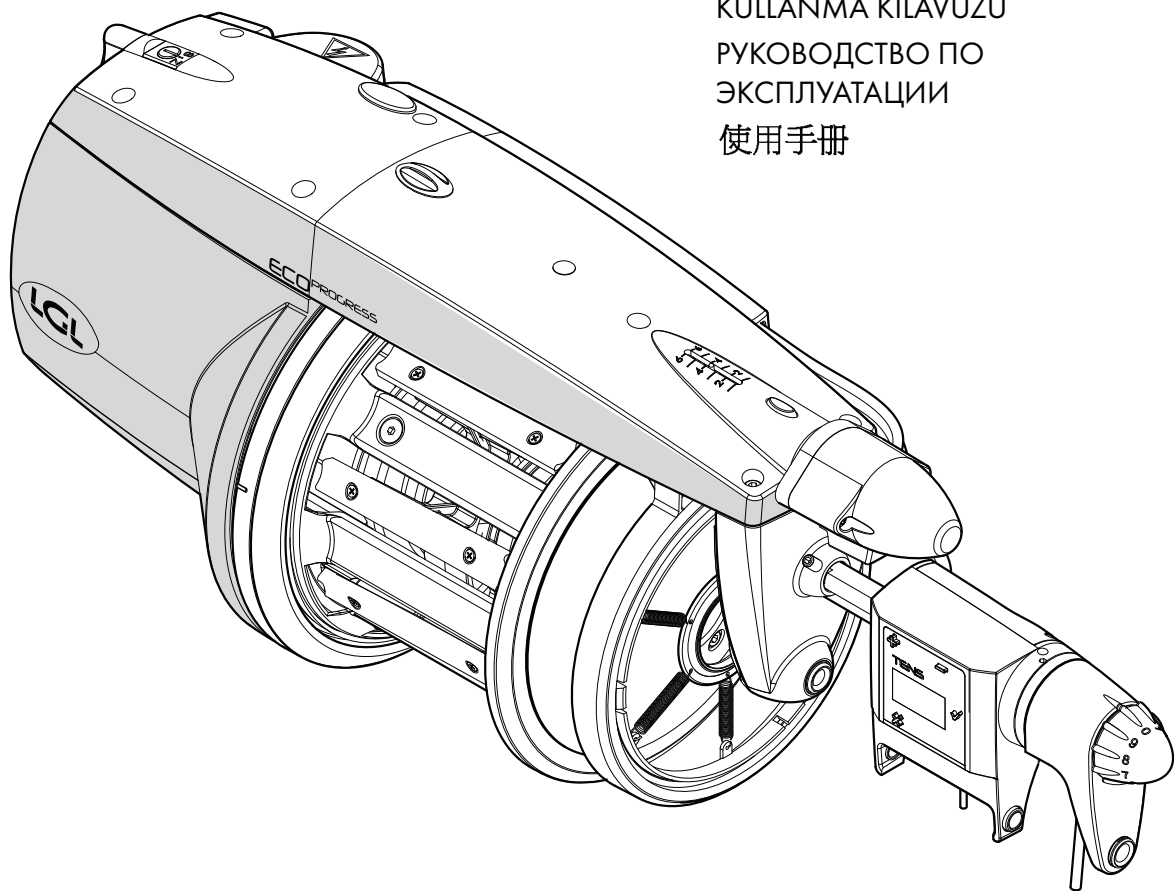

# ECO PROGRESS

MANUALE DI ISTRUZIONE  
INSTRUCTION MANUAL  
NOTICE D'INSTRUCTION  
BEDIENUNGSANLEITUNG  
MANUAL DE INSTRUCCION  
KULLANMA KILAVUZU  
РУКОВОДСТВО ПО  
ЭКСПЛУАТАЦИИ  
使用手册



ALIMENTATORE DI TRAMA A SPIRE SEPARATE REGOLABILI  
WEFT ACCUMULATOR WITH SEPARATE ADJUSTABLE COILS  
DELIVREUR DE TRAME A SPIRES SEPARÉES REGLABLES  
VORSPULGERÄT MIT EINSTELLBAREN SEPARATEN WINDUNGEN  
ALIMENTADOR DE TRAMA DE ESPIRAS SEPARADAS REGULABLES  
IPLIKLER ARASI MESAFESI AYARLANABİLİR ATKI AKÜMÜLATÖRÜ  
НАКОПИТЕЛЬ УТОЧНОЙ НИТИ С РЕГУЛИРУЕМЫМ РАССТОЯНИЕМ МЕЖДУ ВИТКАМИ  
可调节分离线圈导纱器



Scope of supply: Design, manufacture and after sales service of yarn and weft feeders, measuring winders, stands, creels and oil systems for textile machinery.

TRADUZIONI DELLE ISTRUZIONI ORIGINALI.  
TRANSLATION OF THE ORIGINAL INSTRUCTIONS.  
TRADUCTIONS DES INSTRUCTIONS D'ORIGINE.  
ÜBERSETZUNG DER ORIGINALANLEITUNGEN.  
TRADUCCIÓN DE LAS INSTRUCCIONES ORIGINALES.  
ORJİNAL TALİMATLARIN TERCÜMESİ.  
ПЕРЕВОД ОРИГИНАЛЬНОЙ ИНСТРУКЦИИ.  
原始使用说明书的翻译.

L.G.L. Electronics is gratified by your choice  
and thanks you for the preference.

**INSTRUCTION MANUAL**  
**welt accumulator**  
**ECO PROGRESS**

ISSUED BY:

*Bentone Finello*  
S.I.A.C.  
Manager

Date: 01/11/2021

APPROVED BY:

*Giovanni Pedrini*  
Technical Service  
Manager

Date: 01/11/2021

# CAUTION



- 1) Switch off the power supply box and the weft accumulator before starting any connections, maintenance or replacements.
- 2) Switch the weft accumulator off before carrying out any adjustments.



- 3) If the weft accumulator is fitted with a kit for pneumatic threading, discharge all the compressed air before removing the rear cover.
- 4) The weft accumulator can be started, if enabled by the loom, at any time during normal operation, without forewarning.
- 5) Check the feeder to ensure it is intact (flywheel, flywheel bush, moving parts).
- 6) Never touch any moving parts when the equipment is running.
- 7) The machine is not fit to operate in work places featuring high explosion risks.



- 8) Condensation may form on a weft accumulator that has been stored in cold places when this is brought into a warm area. Wait until this is completely dry before connecting it, otherwise the electronic components could be damaged.
- 9) Never take hold of the weft accumulator by the weft spool body or the weft feeler unit.
- 10) Only use original L.G.L. Electronics spare parts and accessories.
- 11) Electronic parts must only be repaired by suitably trained personnel authorised by L.G.L. Electronics.

# CAUTION

**ADVICE TO ALWAYS KEEP THE FEEDER IN PERFECT WORKING ORDER AND EXTEND ITS SERVICE LIFE.**

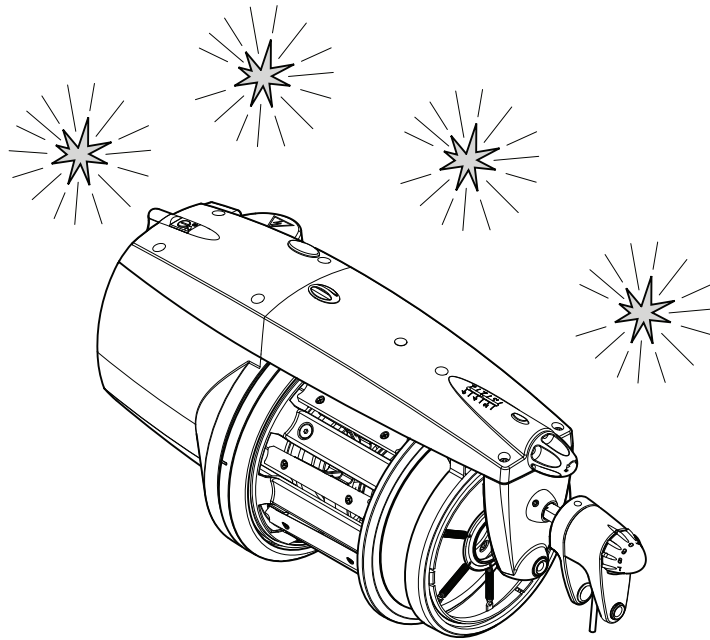

For an always satisfying performance of the weft feeder over the years, we deem it advisable to provide you with some simple tricks:

1. At the time of installation, passing from the store to the warm weaving environment, Condensation may form on a weft accumulator that has been stored in cold places when this is brought into a warm area. Wait until this is completely dry before connecting it, otherwise the electronic components could be damaged.
2. Water and dampness may harm the electronic parts of the feeder. Operating the weft feeder for long time periods in extremely damp environments (dampness exceeding 80%) or using water-impregnated threads might quickly compromise the electronic cards. Moreover, the feeder shall not be cleaned with water or similar substances.
3. Upon installation, before injecting voltage to the feeder, ensure that the round wires are all hooked-up. Any insufficient grounding may damage electronic components.
4. Machines working in environments featuring a lot of dust require increased maintenance. By prevent the weaving environment clean, you avoid residual dirt and dust from compromising the performance of the machine by stressing the moving parts. The latter are protected, but the accumulation of dust might result in a more difficult movement and, as consequence, in early wear-and-tear.

## CAUTION

5. *In the presence of dusty yarns, residual dust or thread may settle on the various parts of the weft feeder. A weft feeder that is particularly dirty is likely to compromise the fabric quality by leaving deposits on the threads that is introduced. In order to improve the fabric in quality as well as the machine overall performance, it is good rule to routinely clean the mechanical moving parts:*
  - *By blowing compressed air from the ceramic of the flywheel, you may clean the shaft channel and remove any residual dust from the input sensor. Warning: Before using compressed air to clean the feeder, ensure you remove the thread from the drum. If you use compressed air with the thread wound up on the drum, you actually risk having the thread get in and accumulate between the flywheel and the drum.*
  - *The drum and the flywheel can be periodically dismantled to remove any residual thread and dust.*
6. *We suggest storing feeders that are not used for long time periods in the special polystyrene boxes, which ensure the best storage.*
7. *When the weft feeder is being loaded, use the special weft taker.*
8. *If the weft feeder is equipped with a TWM brake, always open the brake carriage when you introduce the loading weft taker. Thus, you avoid taking the risk that the weft taker damages the brake unit.*

# INDEX

<b>1</b>	<b>GENERAL FEATURES</b>	<b>9</b>
1.1	Main parts - controls and adjustment points	9
1.2	Overall dimensions	10
1.3	Intended use - main features and specifications	11
1.4	Handling and storage	12
1.5	Input feeler	12
1.6	Optical version	13
1.6.1	Yarn reserve control sensor	13
1.6.2	Output sensor	13
1.7	Mechanical version	14
1.7.1	Minimum reserve sensor	14
1.7.2	Maximum reserve sensor	14
<b>2</b>	<b>INSTALLATION AND START-UP</b>	<b>15</b>
2.1	Installation of the power control box	15
2.2	Can-Bus feature	17
2.3	Installation and start-up of the weft accumulator	17
<b>3</b>	<b>THREADING AND ADJUSTMENTS</b>	<b>18</b>
3.1	Threading of the weft accumulator with weft taker	18
3.2	Pneumatic threading	19
3.3	Speed adjustment	21
3.4	Tension adjustment	21
3.5	Setting the direction of rotation and adjusting the separation of the coils	22
3.6	Mechanical version with 3 weft feelers	24
<b>4</b>	<b>SPECIAL PROGRAMS</b>	<b>25</b>
4.1	Special programs (fitted as standard on all weft feeders)	25
<b>5</b>	<b>MAINTENANCE AND COMPONENT REPLACEMENTS</b>	<b>26</b>
5.1.1	Disassembly of the spool body	26
5.1.2	Removing single parts of spool body	30
5.2	Replacement of the electronic control board	33
5.3	Optical version: calibration of motor sensors, calibration of optical sensors and positioning of the flywheel for pneumatic threading	34
5.4	Mechanical version: calibration of motor sensors and positioning of the flywheel for pneumatic threading	36
<b>6</b>	<b>MOUNTING THE TENSIONERS</b>	<b>38</b>
6.1	Mounting the TWM tension modulator	38
6.2	Mounting the bristle brush	39
6.3	Mounting the metal brush	40

# INDEX

<b>7</b>	<b>APPLICATION FIELD FOR TENSIONERS</b>	<b>42</b>
7.1	Application field for input tensioners	42
7.2	Application field for the "TWM" tension modulator	43
7.3	Application field for bristle brush tensioners	46
7.4	Application field for metal brush tensioners	47
7.5	Yarn count systems conversion table	48
<b>8</b>	<b>TENS AND SRAKE WITH DISPLAY FOR WEAVING MACHINES</b>	<b>49</b>
8.1	Introduction	50
8.2	Before starting	50
8.3	What to do to run the machine	51
8.4	Procedura to go from manual to automatic (and vice versa)	52
8.5	Tension adjusting by setting a desired tension value in cN	53
8.6	Brake opening	53
8.7	Offset	54
8.8	Alarms (only automatic mode)	55
8.9	Examples	56
8.10	Led meaning	56
<b>9</b>	<b>SPECIAL DEVICES</b>	<b>57</b>
9.1	Knot detector	57
9.2	Motor-driven oiling unit	59
9.3	Motor-driven waxing unit	61
<b>10</b>	<b>TROUBLE-SHOOTING</b>	<b>62</b>
<b>11</b>	<b>SCRAPPING</b>	<b>64</b>

# 1 - GENERAL FEATURES

## 1.1 MAIN PARTS - CONTROLS AND ADJUSTMENT POINTS

### Main parts:

- 1 • MOTOR
- 2 • TOP PANEL
- 3 • FLYWHEEL
- 4 • WEFT SPOOL BODY
- 5 • OUTPUT BREAKING UNIT
- 6 • POWER CORD
- 7 • MAIN ELECTRONIC CONTROL BOARD
- 8 • COMPRESSED AIR INTAKE

### Optical version

- 9 • INPUT SENSOR (WEFT BREAKAGE)
- 10 • YARN RESERVE CONTROL SENSOR
- 11 • OUTPUT SENSOR

### Mechanical version

- 9 • INPUT SENSOR (WEFT BREAKAGE)
- 10 • MINIMUM RESERVE SENSOR
- 11 • MAXIMUM RESERVE SENSOR

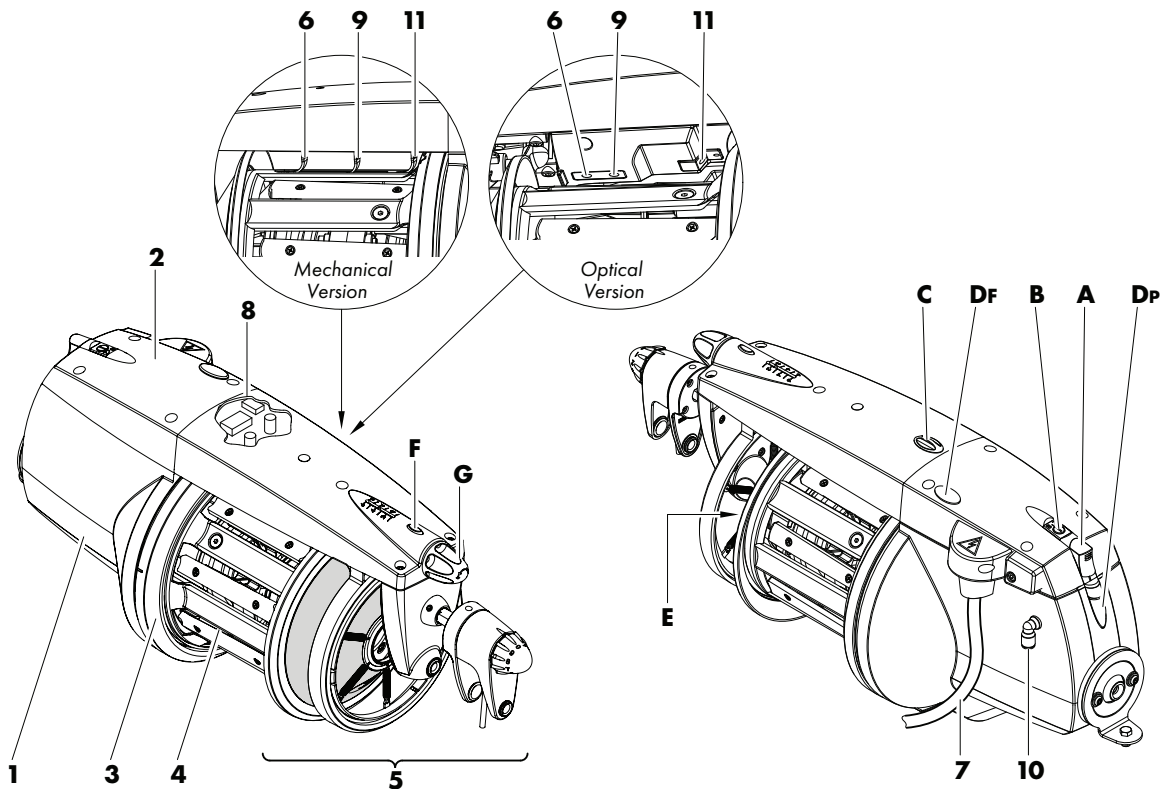

CONTROLS/ADJUSTMENTS		FUNCTION
<b>A</b>	<b>SWITCH 0 - I</b>	<ul style="list-style-type: none"> <li>• Switches the weft accumulator on and off.</li> </ul>
<b>B</b>	<b>SWITCH S - 0 - Z</b> The switch has three positions: <b>S</b> , <b>0</b> (zero) and <b>Z</b> .	<ul style="list-style-type: none"> <li>• For setting the direction of rotation of the motor.</li> </ul> <p><b>N.B.: In cases when the "Loom Stop" function is enabled on the loom, the intermediate position 0 (zero) of the S - 0 - Z switch allows for switching off the weft accumulator that is not used without stopping the loom.</b></p>
<b>C</b>	<b>LED</b>	<ul style="list-style-type: none"> <li>• This comes on and stays on if there are no faults when the accumulator is switched on.</li> <li>• This flashes if there are malfunctions (see paragraph 10 "Trouble-shooting").</li> </ul>
<b>D</b>	<b>PNEUMATIC THREADING BUTTONS</b>	These control the pneumatic threading. <ul style="list-style-type: none"> <li>• Button <b>Dp</b> for partial threading (up to weft spool body).</li> <li>• Button <b>Df</b> for total threading.</li> </ul>
<b>E</b>	<b>COIL ADJUSTMENT BUTTON</b>	<ul style="list-style-type: none"> <li>• This is used to vary the separation of coils (see paragraph 3.5 "Setting the direction of rotation and adjusting the separation of the coils").</li> </ul>
<b>F</b>	<b>RELEASE PUSH-BUTTON</b>	<ul style="list-style-type: none"> <li>• This is for releasing the output tensioner.</li> </ul>
<b>G</b>	<b>ADJUSTMENT KNOB</b>	<ul style="list-style-type: none"> <li>• This is for adjusting the intensity of the output tensioner.</li> </ul>

# 1 - GENERAL FEATURES

## 1.2 OVERALL DIMENSIONS

### ECOPROGRESS with TWM tension modulator

Weight 6,8 Kg

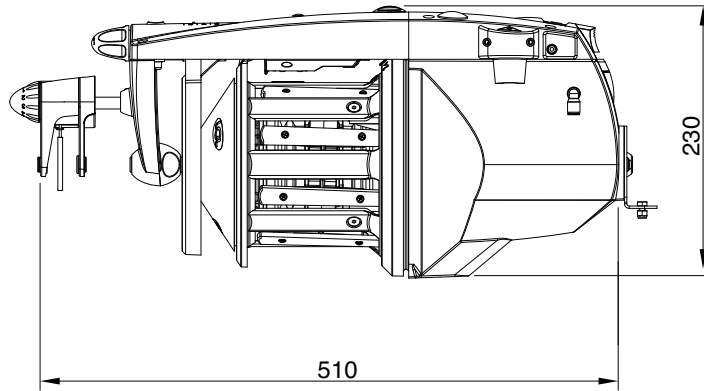
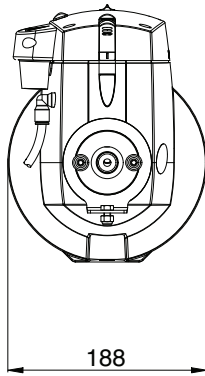

### ECOPROGRESS with TENS

Weight 7 Kg

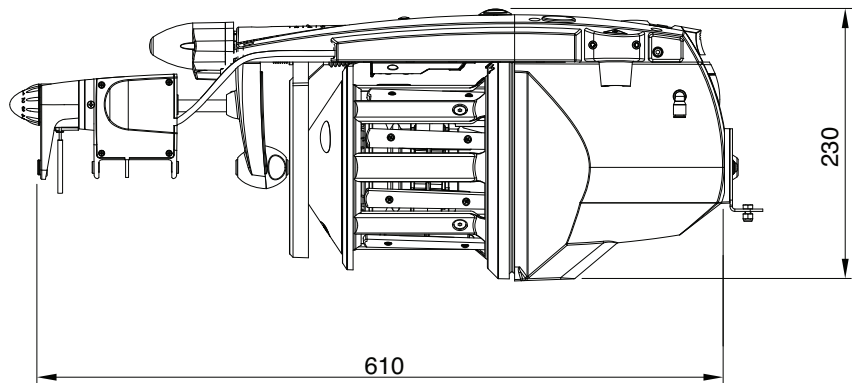
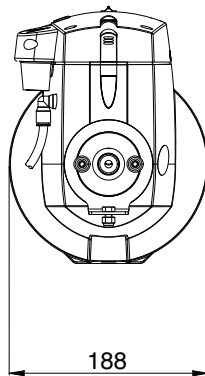

# 1 - GENERAL FEATURES

## 1.3 INTENDED USE - MAIN FEATURES AND SPECIFICATIONS

### Intended use:

The ECOPROGRESS is a weft accumulator with **separate adjustable coils** that can be used on all gripper and projectile weaving machines.

It can work with yarn counts ranging from **9000 DEN** (thick wefts) to **5 den** (fine wefts).

### Main features:

- Automatic speed control to suit the loom's weft quantity requirements.
- Direction of rotation can be inverted for **S** or **Z** twisted yarns.
- Weft reserve control using an optical or mechanical system, 100% dust, light and smear-proof.
- The possibility, depending on the weaving conditions, to adopt different work programs thanks to different DIP-SWITCH combinations.
- Pneumatic threading.
- If an input sensor (optional) is fitted, the following functions can be carried out:
  - **"Loom stop"**: It stops the weft accumulator and the loom automatically if there is no weft detected at the accumulator input (broken weft or end spool).
  - **"Exclusion of broken wefts"**: It excludes broken wefts automatically by stopping the accumulator but without stopping the loom if no weft is detected at the accumulator input (broken weft or end spool). This function is only possible on weaving machines equipped for this function.
- Various tensioners can be fitted at the weft accumulator input and output to suit the yarn being woven.
- Possibility to interface-connect the feeder with the weaving machine through the Can-Bus protocol.

### Technical specifications:

- Power supply box supplied separately by LGL Electronics.  
**V = 140/300 Vdc**
- Automatic weft accumulation speed control up to max. **1800 m/min.**
- Adjustable coil separation from **0** to max **4 mm**
- Brush less motor, maintenance-free:  
Motor data:  
Max. power: **130 W**      Average absorbed power: **20 W**
- Acoustic pressure level **A**, at max. speed, less than **70 dB**
- Pneumatic circuit pressure: min. **5 bar**; max. **7 bar**
- Operating conditions - Storing conditions:  
Temperature: **+10** to **+40 °C**  
Max. humidity: **80%**

# 1 - GENERAL FEATURES

## 1.4 HANDLING AND STORAGE

**Never take hold of the weft accumulator by the weft spool body or weft feeler unit.**

**YES**

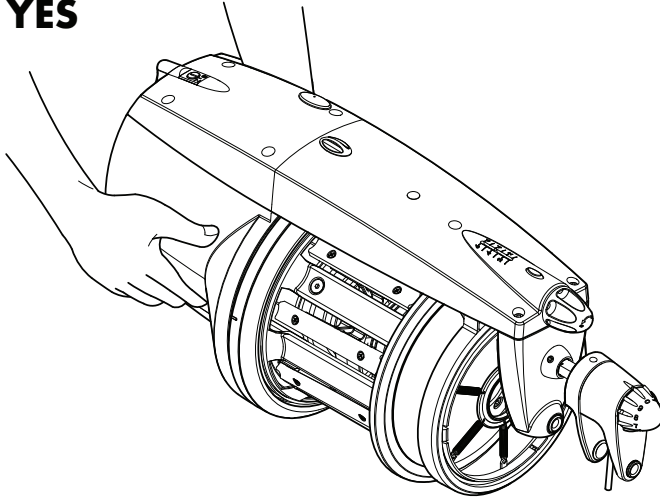

**NO**

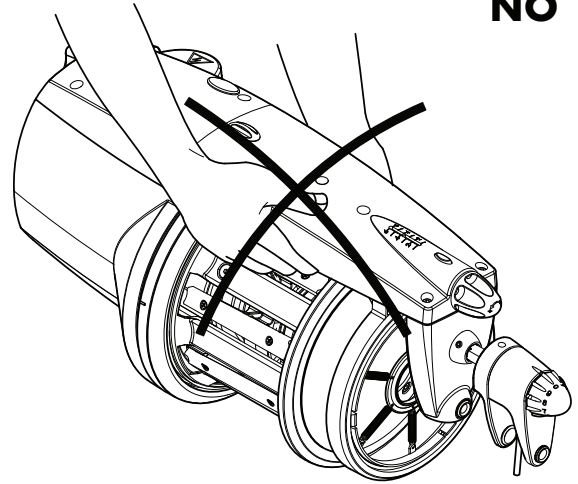

The weft accumulator is supplied with its own polystyrene casing: keep this in a safe place for future use.

## 1.5 INPUT FEELER

The yarn feeder features an input feeler that provides the following function:

- **“Machine stop” function:** this function stops both the feeder and the machine if no yarn is detected at feeder input (broken yarn or empty yarn spool).

### MECHANICAL VERSION

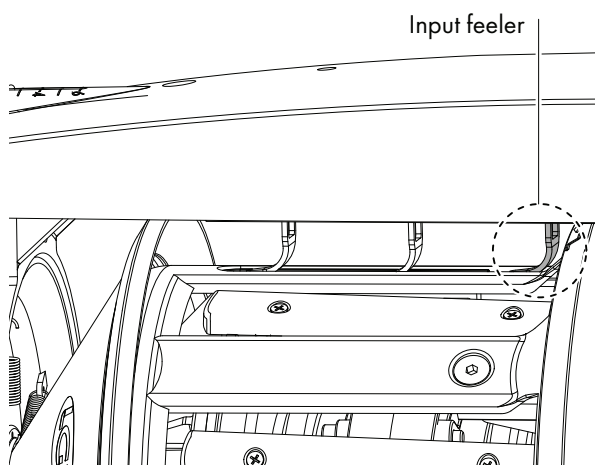

### OPTICAL VERSION

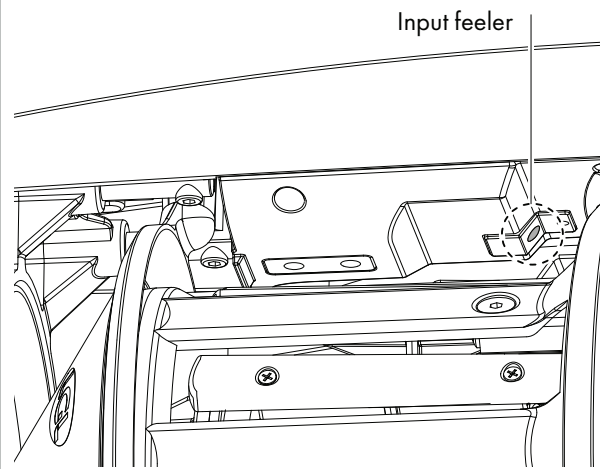

# 1 - GENERAL FEATURES

## 1.6 OPTICAL VERSION

### 1.6.1 YARN RESERVE CONTROL SENSOR

The sensor that the feeder is equipped with has the function of monitoring the yarn reserve on the drum.

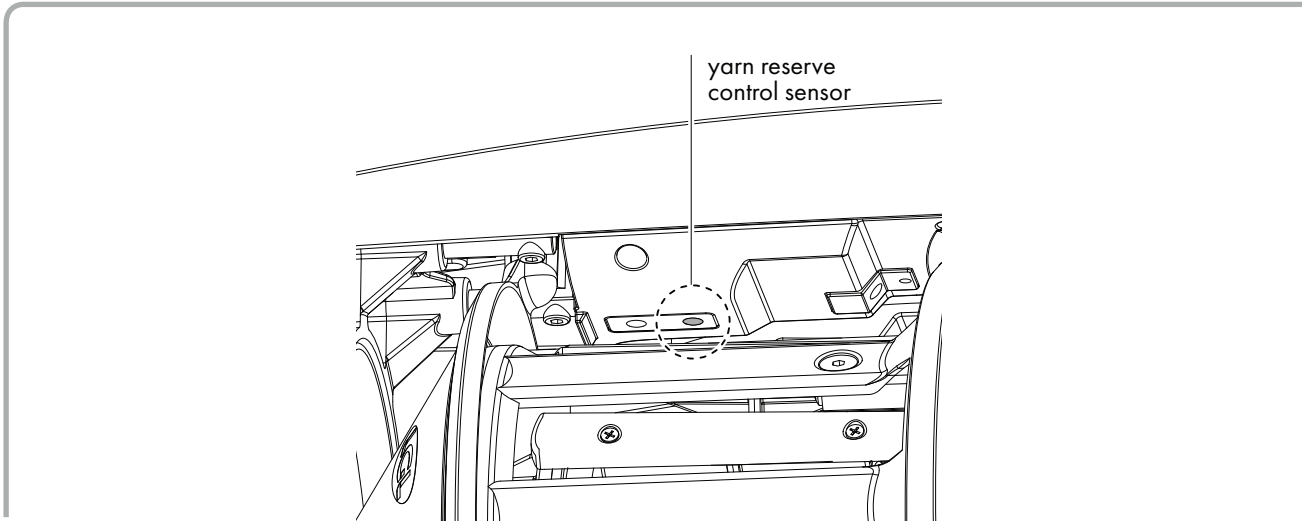

### 1.6.2 OUTPUT SENSOR

The sensor featured by the yarn feeder provides automatic speed adjustment based on the quantity of yarn needed by the machine. For processing very fine yarns (less than 40 den), it requires DIP SWITCH setting (see Chapter 4).

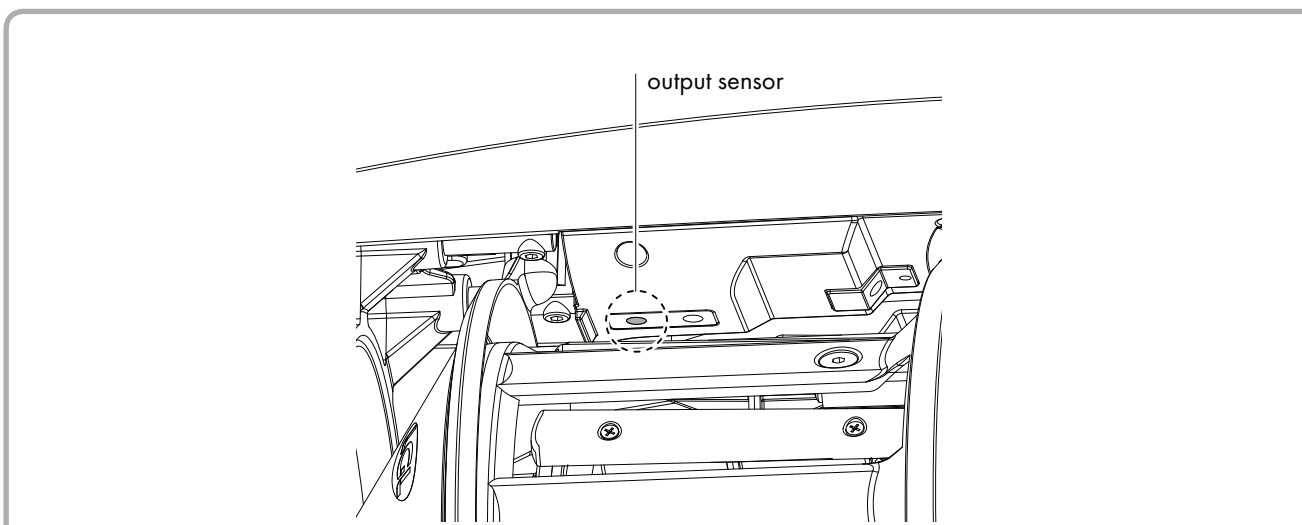

# 1 - GENERAL FEATURES

## 1.7 MECHANICAL VERSION

### 1.7.1 MINIMUM RESERVE SENSOR

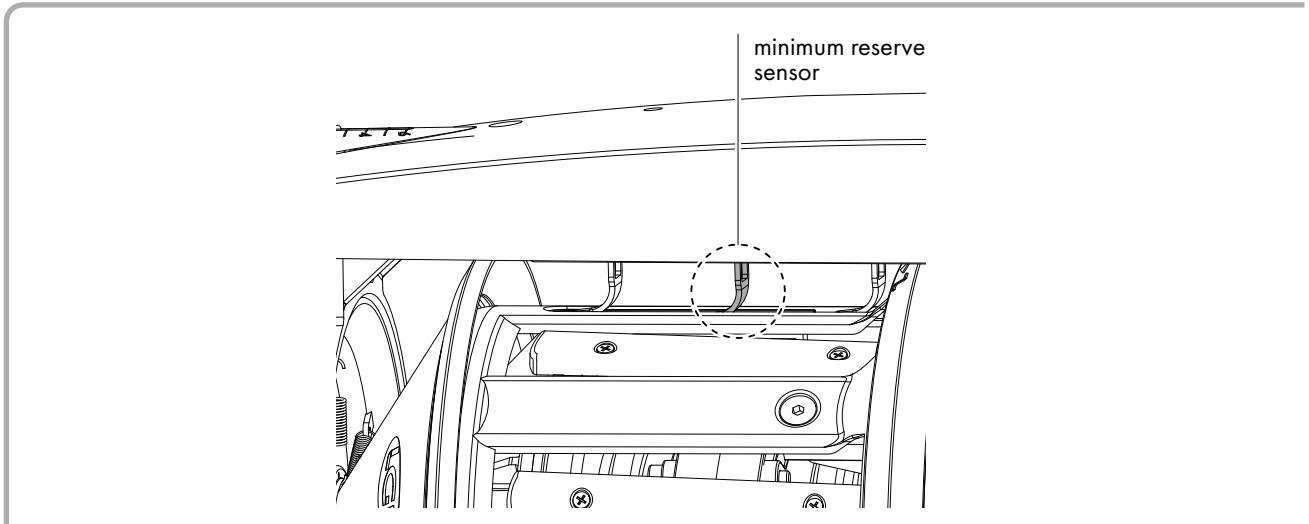

### 1.7.2 MAXIMUM RESERVE SENSOR

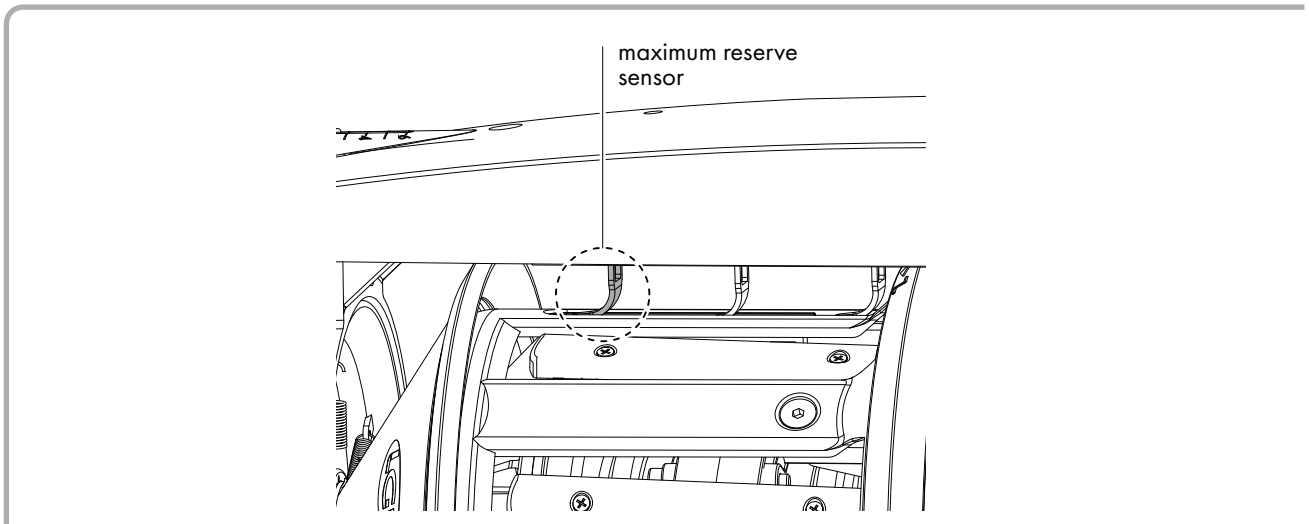

**N.B:** do not rotate the weft spool body before removing the top panel as it would damage the sensor levers.

# 2 - INSTALLATION AND START-UP

## 2.1 INSTALLATION OF THE POWER CONTROL BOX

To install the power supply box, follow these steps:

- 1) Fix the power supply box to the support with the clamp(s) provided at least 30 cm from the ground.

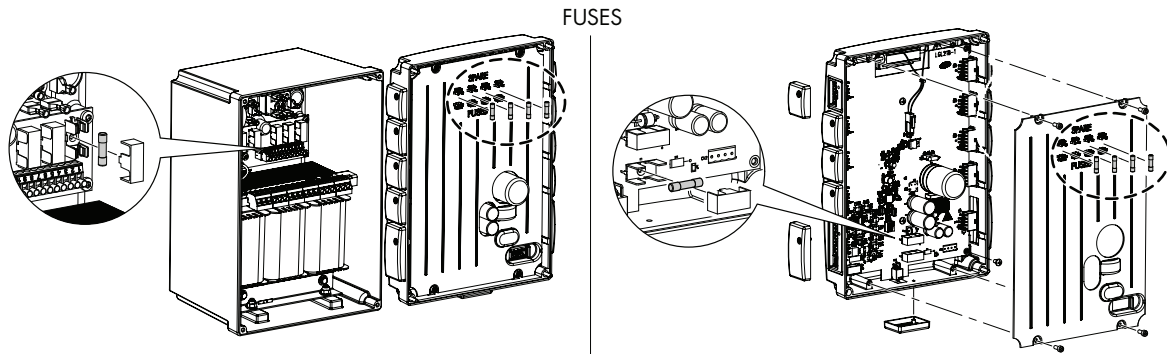

DC POWER BOX

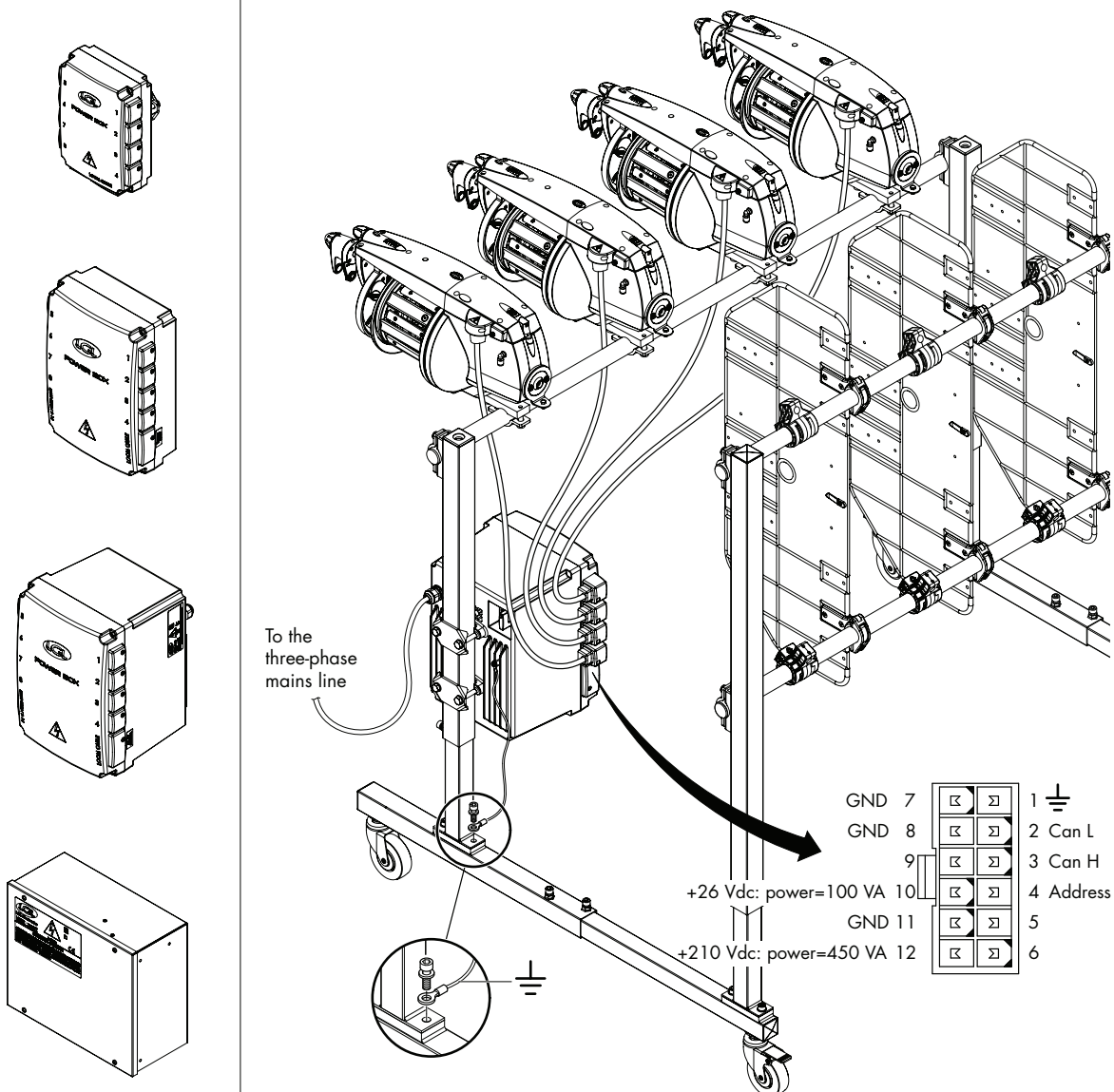

## 2 - INSTALLATION AND START-UP



**Check that the power supply box is set for the right supply voltage.**

See the ratings sticker on the outside of the power supply box.

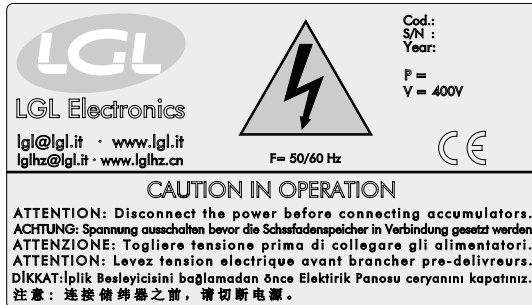

- 3) Connect the power supply box cable to the three-phase mains line.  
For the connections, see the drawing enclosed in the box.



**N.B.: Make all connections to the three-phase mains line downstream of the main switch on the loom so that it can also act as a switch for the power units on the loom.**

- 4) Connect the power supply box earth cable to its stand base.



**WARNING: Switch off the power supply box before making any connections.**

AC POWER BOX

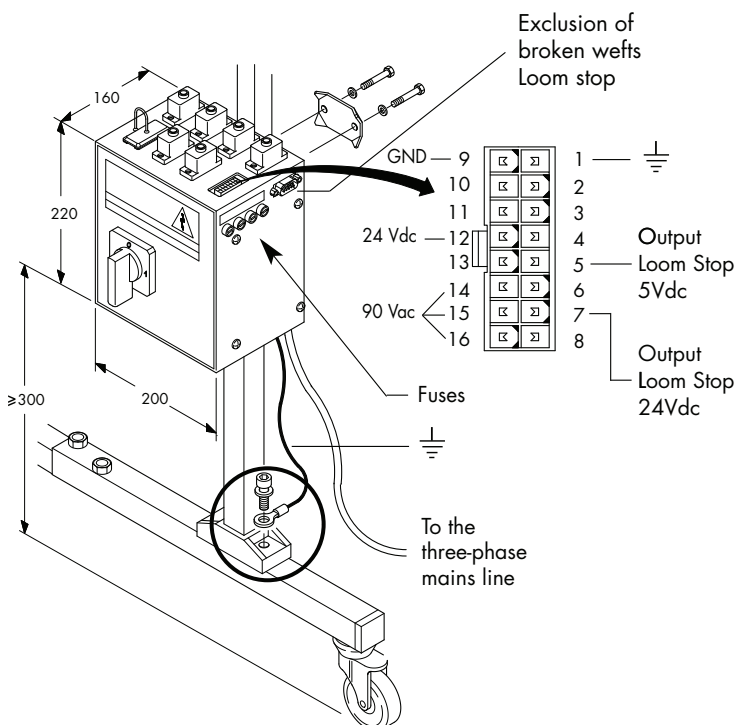

**NB:** If you want to use old power box, you must use special power cable with a specific adapter  
AC POWER BOX STD:  
A1C3SA004-STD15  
AC POWER BOX CAN BUS:  
A1C3SA004-CB15

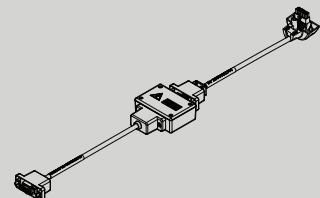

# 2 - INSTALLATION AND START-UP

## 2.2 CAN-BUS FEATURE

The ECOPROGRESS feeders incorporate a dual communication system with the weaving machine. They can either operate with the traditional system and with the new Can-Bus protocol, provided that a dedicated Cable - Power Supply Box equipment is available.

Notably, if the feeder operates with the Can-Bus protocol, it may exchange a greater number of data with the weaving machine and hence incorporate new features.

The **PATTERN PREVIEW**, which the feeder can use to improve speed adjustment, is an instance of this improved feature.

The weaving machine communicates in advance which feeder will be selected and for how long it will operate. Then the feeder will use this information to optimize its acceleration ramp and set a dedicated winding speed in shorter time lags.

## 2.3 INSTALLATION AND START-UP OF THE WEFT ACCUMULATOR

**N.B.: Condensation may form on a weft accumulator that has been stored in cold places when this is brought into a warm area. Wait until this is completely dry before connecting it, otherwise the electronic components could be damaged.**

To install and start-up the weft accumulator, follow these steps:

- 1) Fix the accumulator to its stand using the clamp provided.  
**N.B.: Make sure that the stand used to hold the weft accumulator is connected to the earth system.**
- 2) Position the weft accumulator so that the weft is as straight as possible between this and the loom.
- 3) If necessary (e.g. highly twisted yarns, snarled yarns, etc.), fit the input tensioner to the weft accumulator if not already fitted on the creel.
- 4) Connect the weft accumulator to the pneumatic circuit (only if fitted with pneumatic threading).
- 5) **Switch off the power supply box before connecting the weft accumulator.**  
*This is necessary in order not to damage the weft accumulator electronics.*
- 6) MeSwitch off the weft accumulator by turning its **0 - I** switch to **0**.
- 7) Connect the weft accumulator cable to a power supply box socket.  
**N.B.: the power supply cable must be connected to the socket marked with the same number as the finger of the loom to be fed by the weft feeder.**
- 8) Switch on the power supply box.  
The green led on the accumulator top panel will flash briefly and then go off (Reset).
- 9) Set the weft accumulator direction of rotation and adjust the coil separation.  
The default settings for the accumulators are **Z** rotation.
- 10) Now thread up the weft accumulator using the special weft taker provided or the pneumatic threading system, if fitted.
- 11) Having threaded up the accumulator, switch it on by turning switch **0 - I** to **I** and the weft will start to be wound around the weft spool body.

# 3 - THREADING AND ADJUSTMENTS

## 3.1 THREADING OF THE WEFT ACCUMULATOR WITH WEFT TAKER

Always switch off the accumulator before any threading operation as shown in the figures below:

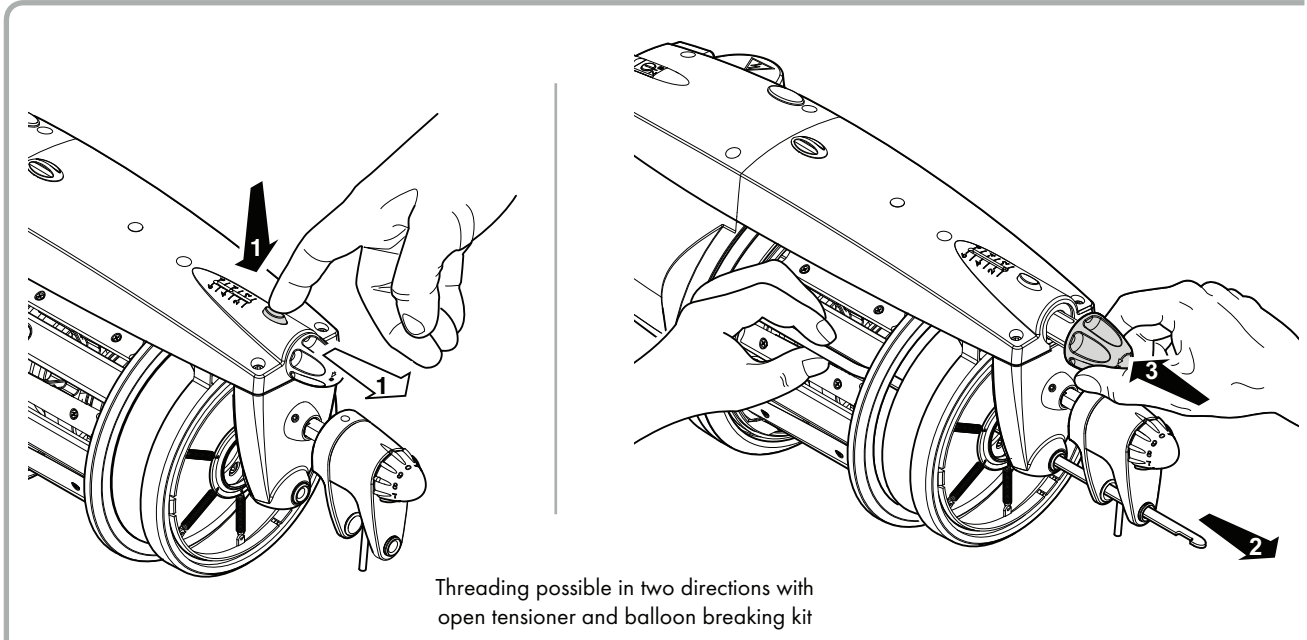

**To avoid damaging the TWM on the outer edge it is advisable to operate the threading with the TWM open, by taking the actions listed below:**

- Open the TWM by pressing the release push-button;
- Insert the taker up to the output yarn guide;
- Hook the thread to the taker and thread it.
- After threading, place the balloon breaking kit back in place and close the output tensioner by pressing knob (G).

**To avoid damaging the BRAKE we recommend using weft takers supplied by LGL electronics.**

# 3 - THREADING AND ADJUSTMENTS

## 3.2 PNEUMATIC THREADING

Pneumatic threading can be:

**PARTIAL:** To thread the back of the accumulator up to the weft spool body.

**TOTAL:** To thread the back of the accumulator up to the weft spool body and then on to the front, from the weft spool body to the output.

### Specifications:

Compressed air pressure: min. **5 bar**; max. **8 bar** (we recommend **6 bar**).

Air tube diameter: **6x4 mm**;

Use dry air only.

### Threading procedures:

#### **PARTIAL (up to the weft spool body)**

When required:

- Accumulator in alarm (end spool);  
Weft still on the front section of the weft spool bod

Threading procedure:

- 1) With one hand take the weft to ceramic bush (1) and with the other press button (**DP**).
- 2) Knot the new weft to the end of the old weft on the front section of the weft spool body.
- 3) Switch the accumulator off and then back on again for the weft to be wound as normal.

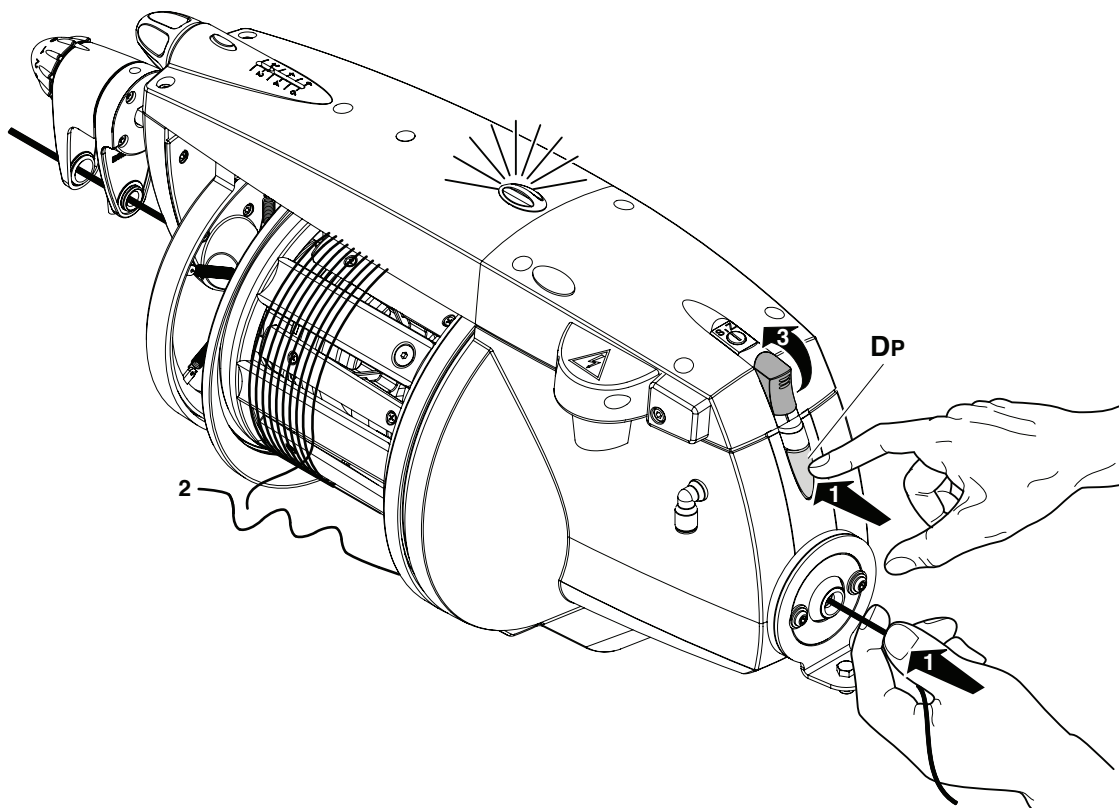

# 3 - THREADING AND ADJUSTMENTS

## TOTAL

- 1) Open the output tensioner by pressing push-button **(F)**.
- 2) With one hand take the yarn to ceramic bush **(H)** and with the other press button **(Dt)** until the yarn moves out of the output yarn guide.
- 3) After threading close the output tensioner by pressing knob **(G)**. Switch on the yarn feeder for start winding the yarn on the spool body.

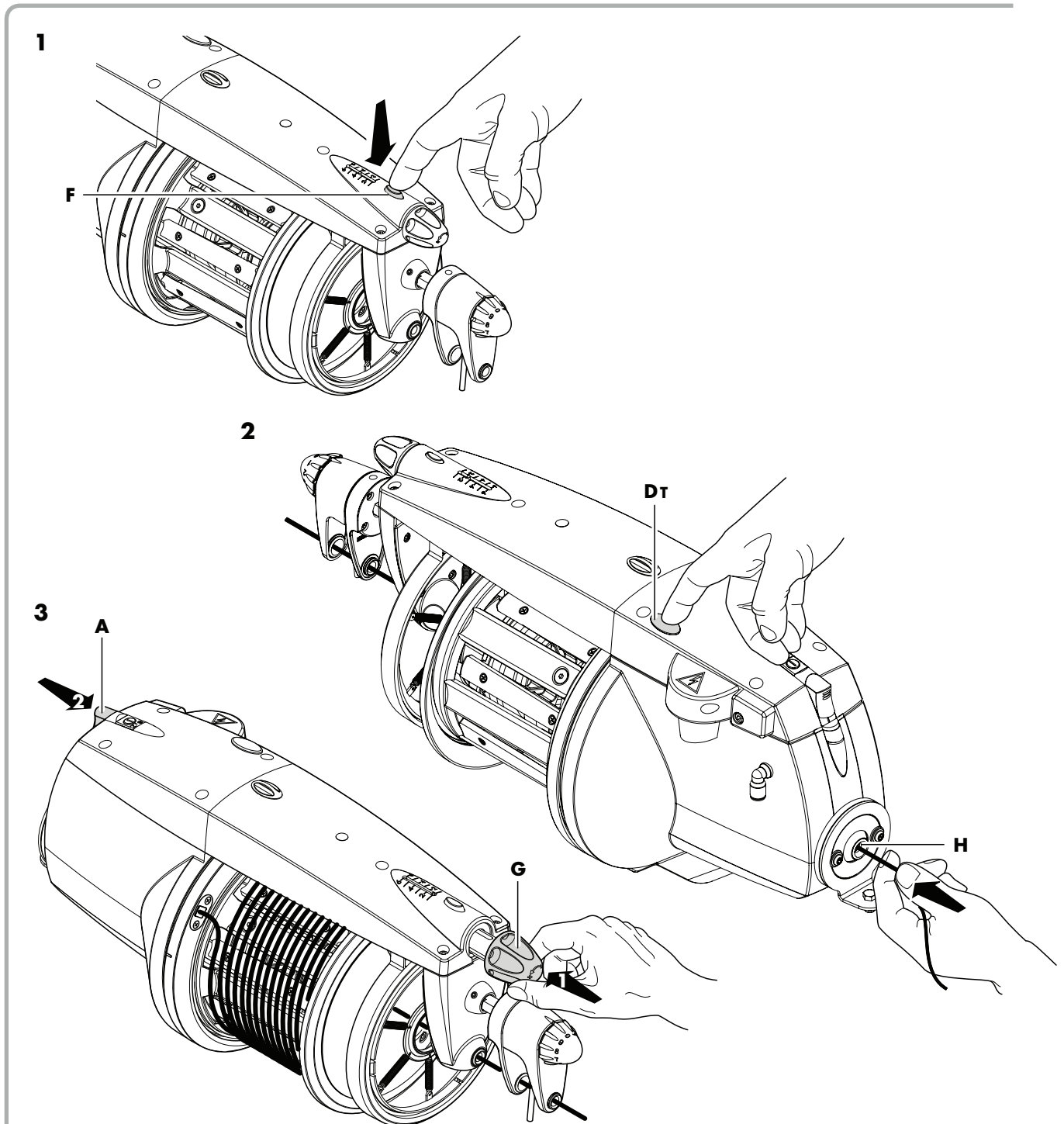

## CAUTION

The functionality of the total threading provides automatic positioning of the flywheel. This functionality is default enabled on the switched on yarn feeder by DS4 (see Chapter 4).

# 3 - THREADING AND ADJUSTMENTS

## 3.3 SPEED ADJUSTMENT

The ECOPROGRESS is equipped with a microprocessor and an output sensor that automatically adjust the winding speed to suit the insertion speed of the loom.

## 3.4 TENSION ADJUSTMENT

Use the output and input tensioners (the latter are not always fitted) on the accumulator to adjust the tension to suit the yarn being used.

Here are a few examples:

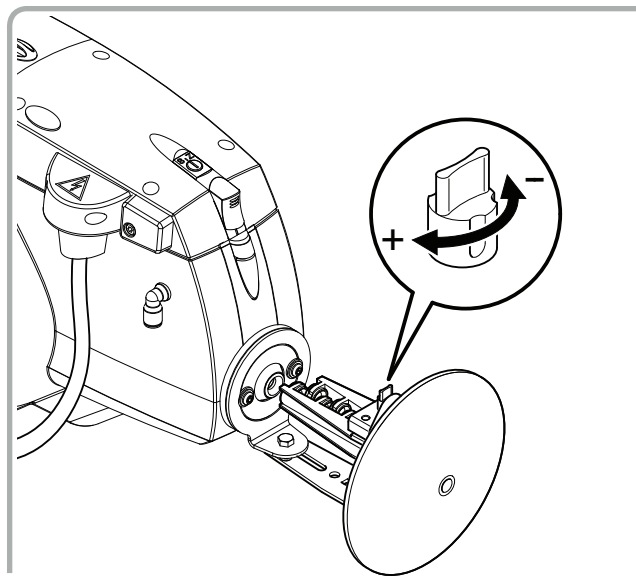
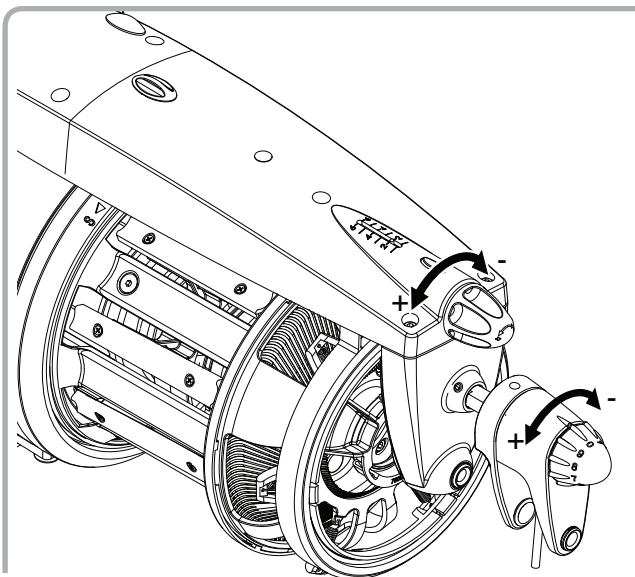
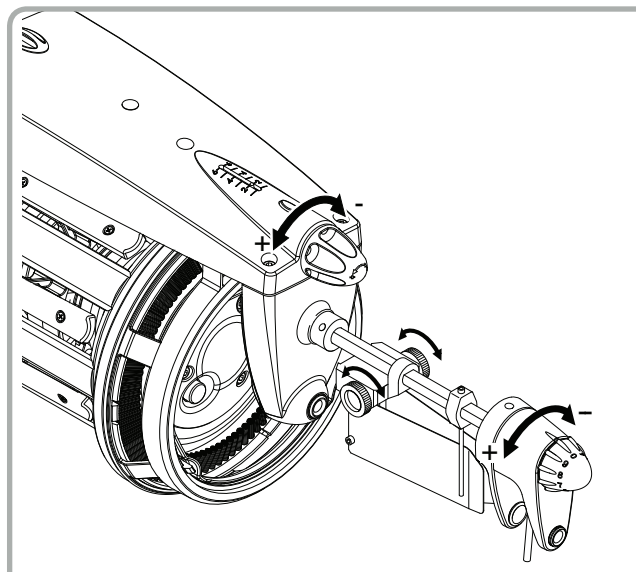
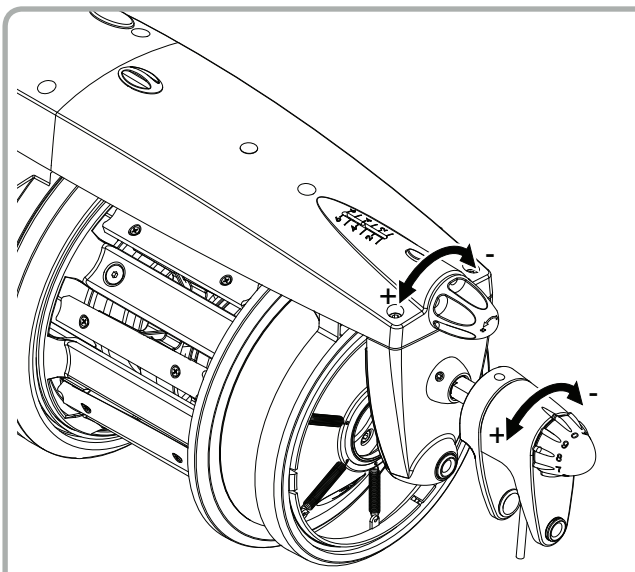

# 3 - THREADING AND ADJUSTMENTS

## 3.5 SETTING THE DIRECTION OF ROTATION AND ADJUSTING THE SEPARATION OF THE COILS

The ECOPROGRESS allows for the adjustment of the coil separation from **0** to max. **4 mm**, regardless of whether the weft twist is **S** or **Z**.

- 1) Set the direction of rotation (**S** or **Z**) by moving switch **S - o - Z** to the required position and then adjust the coil separation as follows:
- 2) Push button (**E**) and hold down to make flywheel (**L**) turn until the button engages.

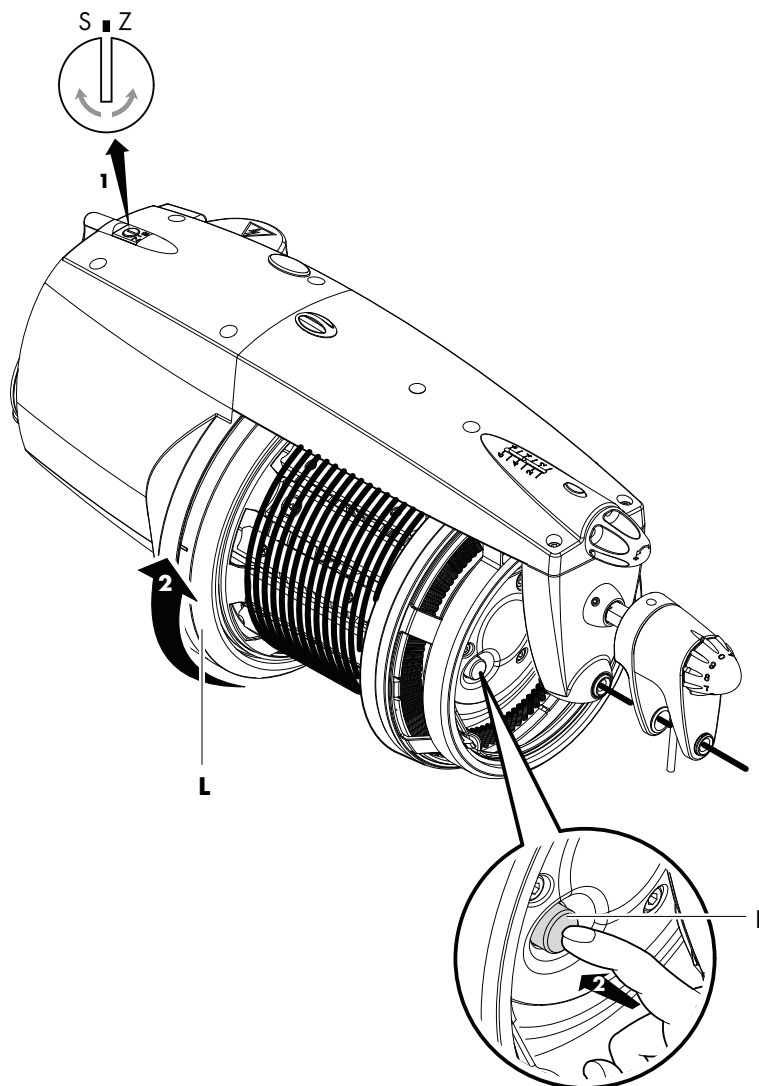

## 3 - THREADING AND ADJUSTMENTS

- 3) With the button held down, jog the flywheel a little (about 1 cm) in the same direction of rotation as the accumulator (set by switch **S** - o - **Z**) and then release the button.  
(If the direction of rotation of the accumulator is S, the flywheel must also turn in the S direction, and vice-versa).
- 4) Switch on the accumulator and check the coil separation.  
If the coil separation is not correct, repeat the above steps (points **2** and **3**), making the flywheel turn in the same direction as the accumulator to increase the separation and in the opposite direction to decrease.

**Z MAX**

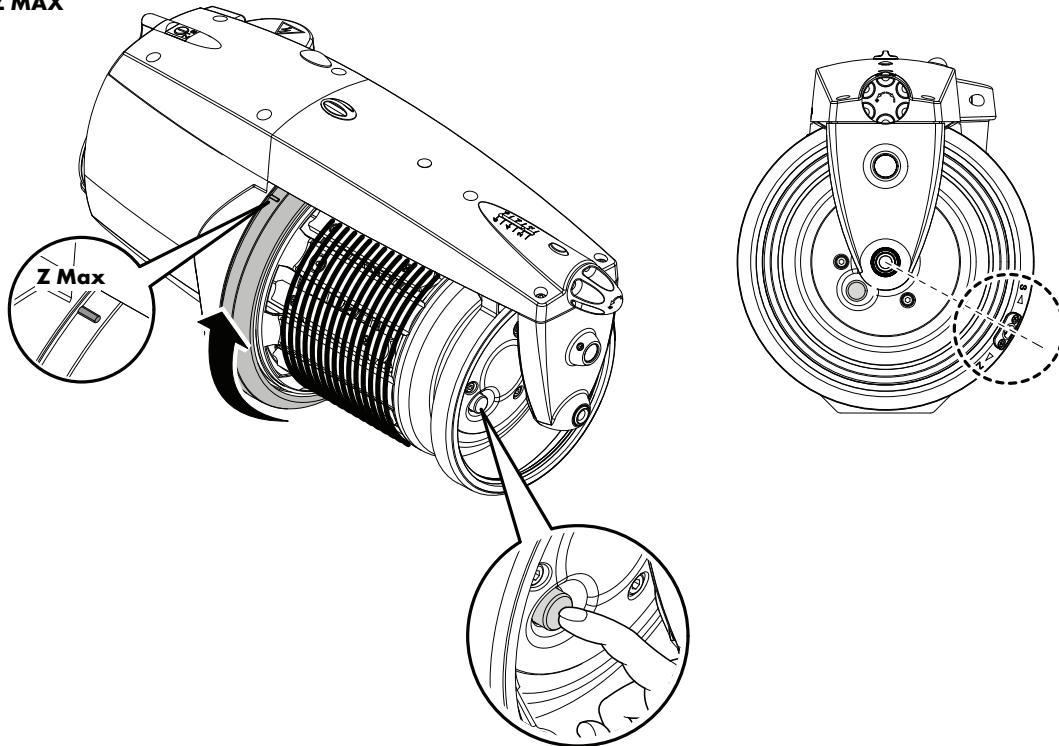

**S MAX**

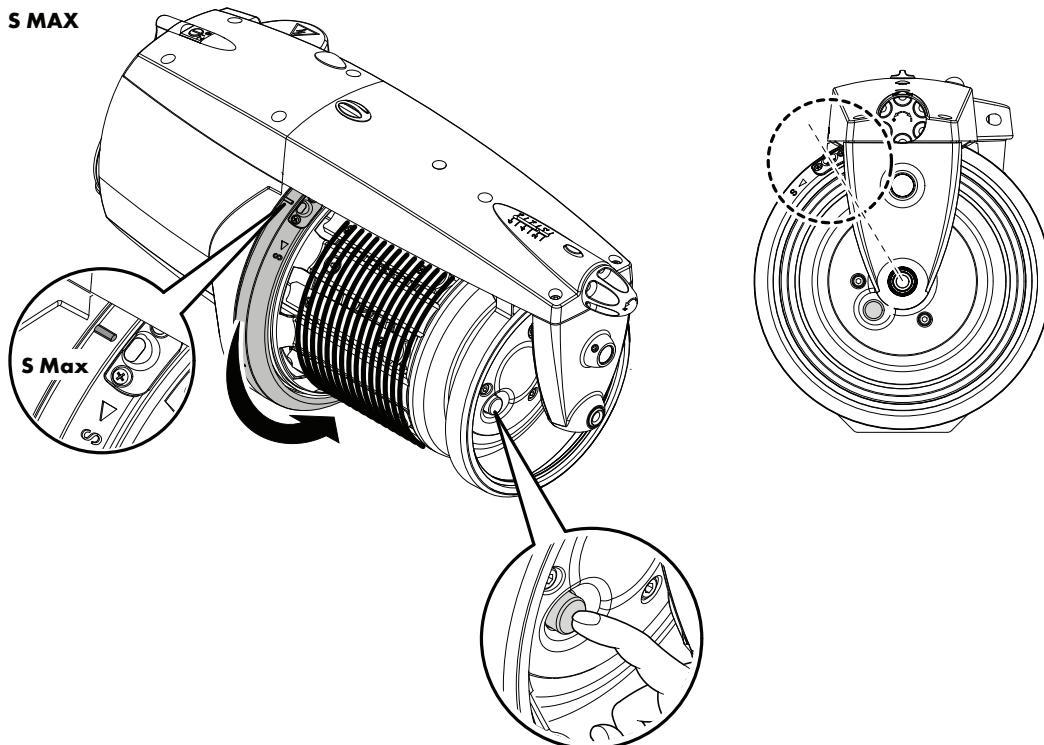

# 3 - THREADING AND ADJUSTMENTS

## 3.6 MECHANICAL VERSION WITH 3 WEFT FEELERS

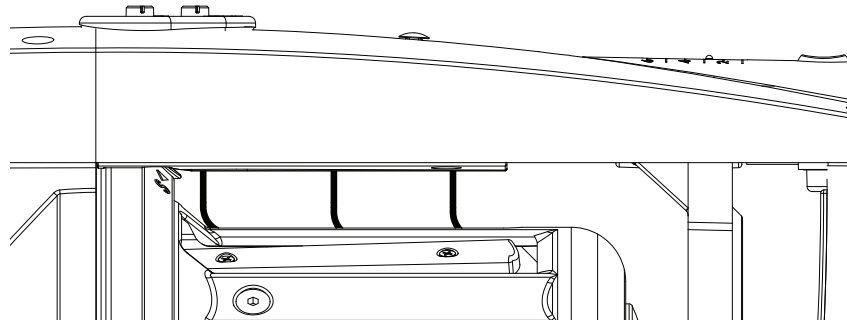

In the mechanical version with 3 weft feelers, the levers can be adjusted at various force levels, depending on the type of yarn counts used.

Notably, the input sensor can be adjusted to 2 levels using the selector switch **(A)**; the minimum reserve sensor and maximum reserve sensor can be adjusted to 4 different levels, both using selector switch **(B)**.

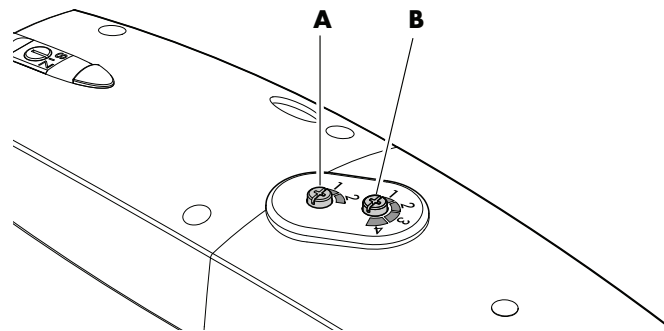

**N.B:** In case the weft feelers swing excessively, it is recommended to increase the force level.

Feeders with 3 weft feelers can be fitted on supports at a maximum inclination of 45°. The inclination is reduced to 15° if the minimum force levels are used.

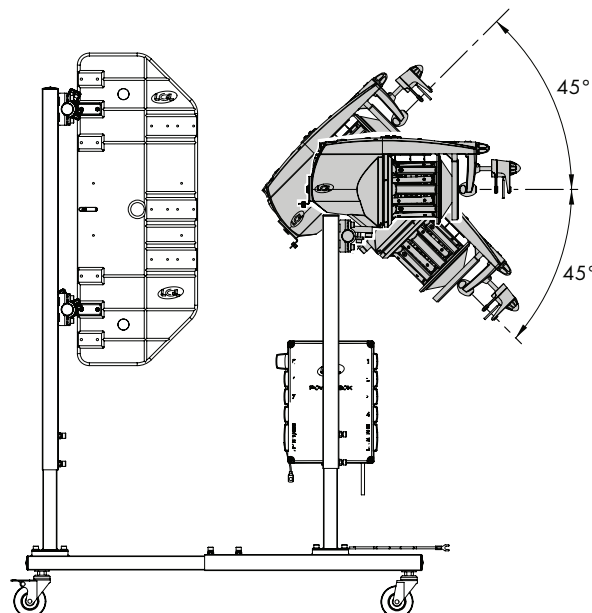

# 4 - SPECIAL PROGRAMS

## 4.1 SPECIAL PROGRAMS (fitted as standard on all weft feeders)

All weft feeders have a series of special operating programs that can be enabled by simply changing the combination of the DIP-SWITCHES on the electronic control board.

**DS02:** if it is set to OFF position ( default ) the standard acceleration is selected ; if it is set in ON position the low acceleration is selected ( suggested for very delicate yarns ).

**DS03:** if DS3 is set in OFF position ( default ) pattern preview is disabled. If DS3 is set in ON position the pattern preview is enabled.

**DS04:** if it is in ON position the flywheel positioning for the automatic thread in is disabled. If it is in OFF position (default) then the flywheel positioning is enabled. Note that the positioning is executed **ONLY** on an input yarn breakage event.

If it is in the ON position, the positioning of the flywheel for pneumatic threading is disabled.

### ONLY FOR OPTICAL VERSION:

**DS01:** if it is in OFF position ( default ) the standard photocells sensibility is selected ( suggested for yarn count > 40 den ); if it is set in ON position the high photocells sensibility is selected ( suggested for very fine yarn or a yarn count <= 40den ).

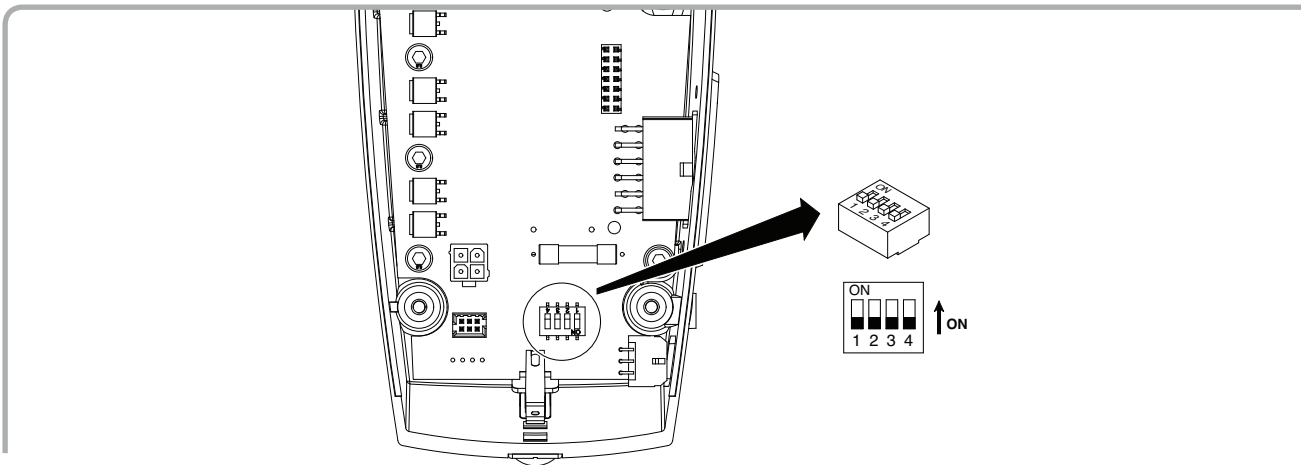

# 5 - MAINTENANCE AND COMPONENT REPLACEMENTS

## 5.1.1 DISASSEMBLY OF THE SPOOL BODY

In order to remove the weft spool body, follow these steps:

- 1) Switch off the yarn feeder by turning **0 - I** switch to **0**.



- 2) Turn off the power supply using the main switch on the textile machine.
- 3) Remove the power cable connector from the yarn feeder cover by unscrewing the 2 fixing screws.

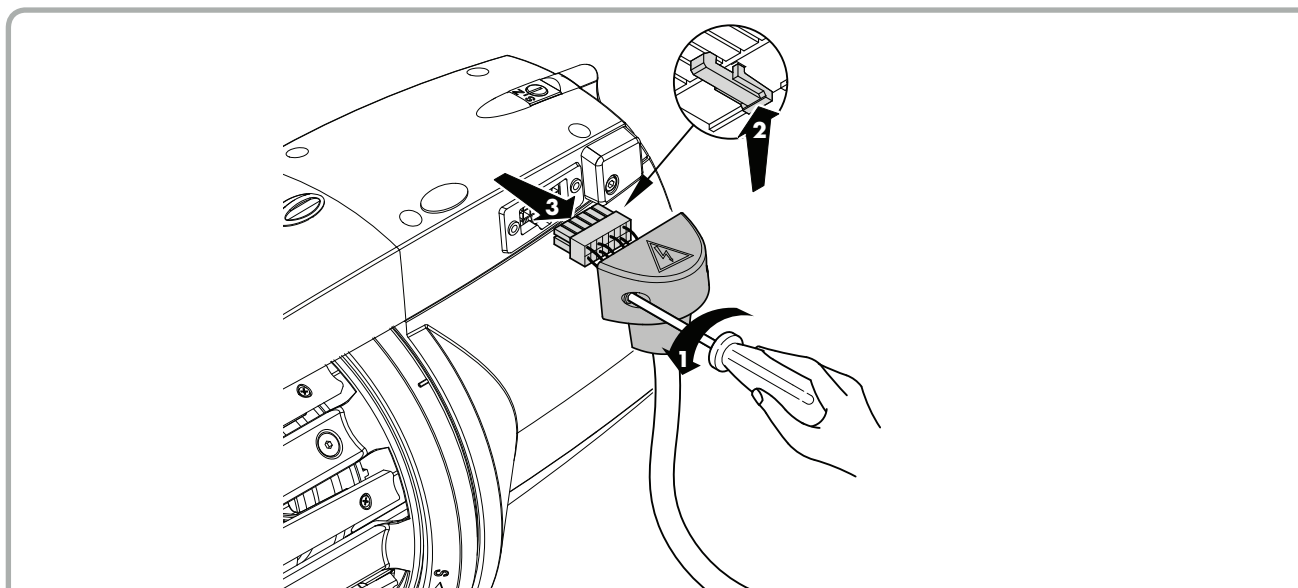

- 4) Unscrew the 4 screws (1), lift and remove the cover (2), releasing it from the cables and tubes coming from the body.

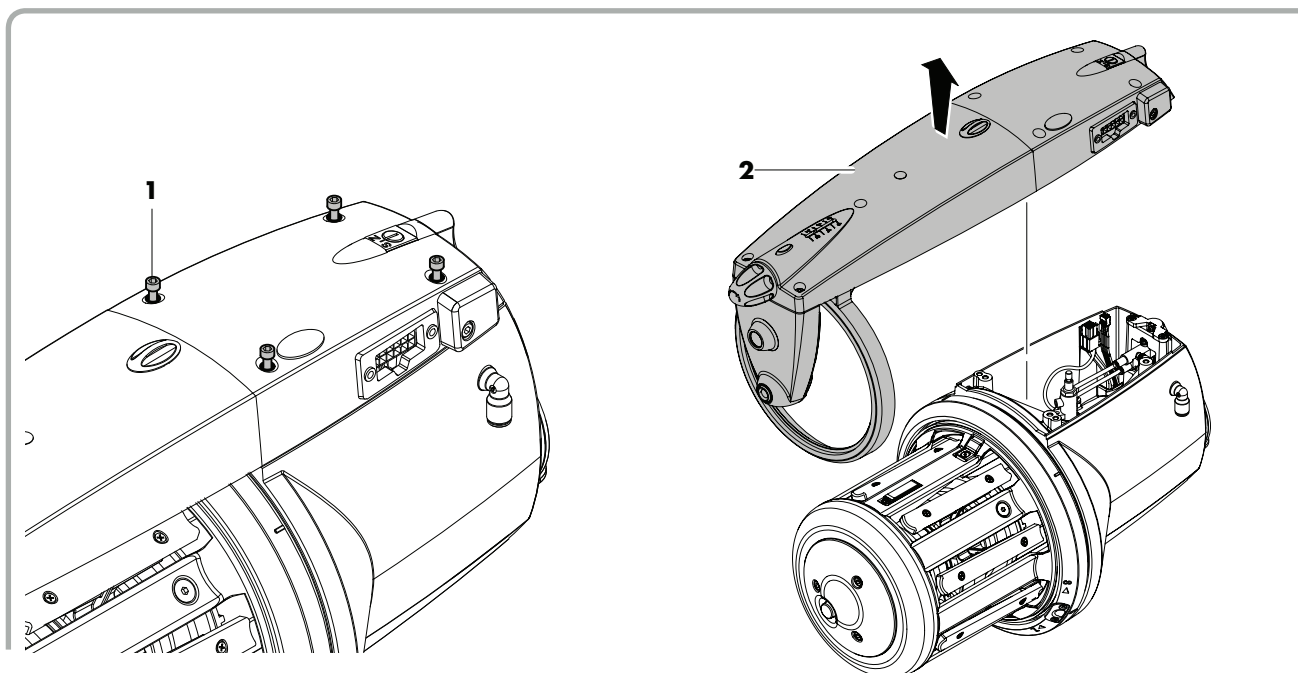

## 5 - MAINTENANCE AND COMPONENT REPLACEMENTS

- 5) Remove the front cap, unscrew the center screw of the spool body and pull out the balancer. For placement make sure to correctly align the S / Z bush inside the spool body with the ceramic bush on the flywheel. The central screw must be closed at 3.5 Nm

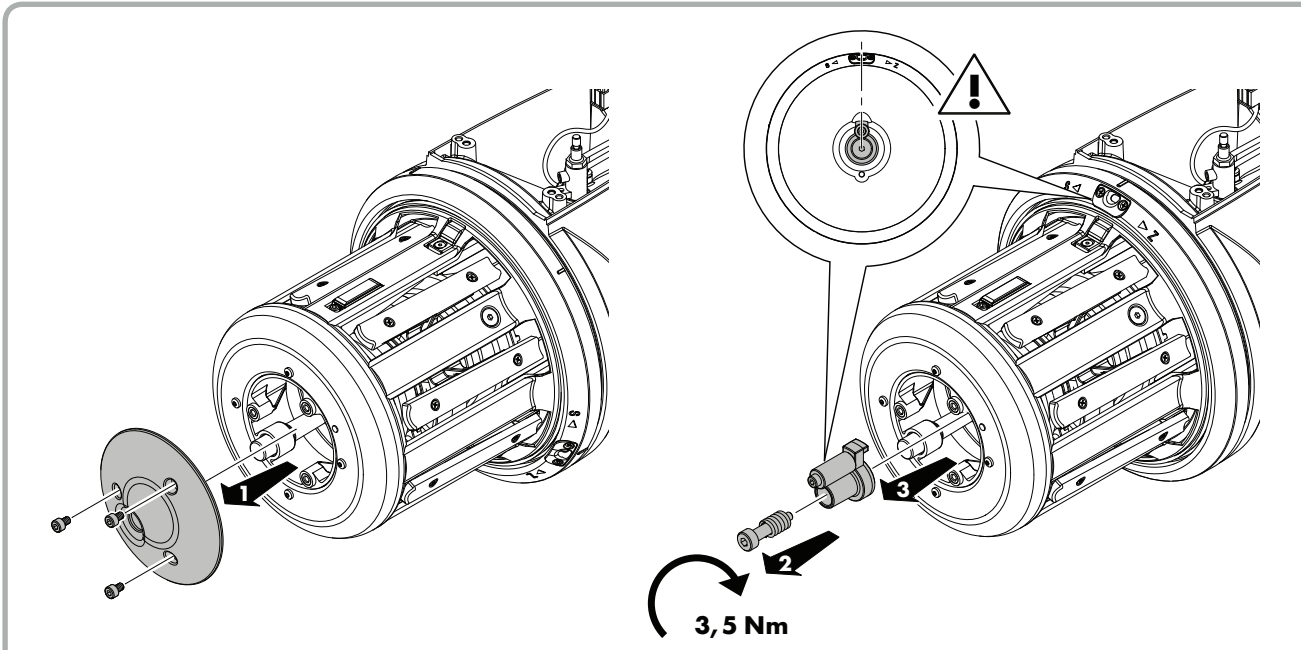

It is now possible to remove the full spool body from the shaft.  
It is also possible to remove the flywheel and replace the ceramic inside the shaft.

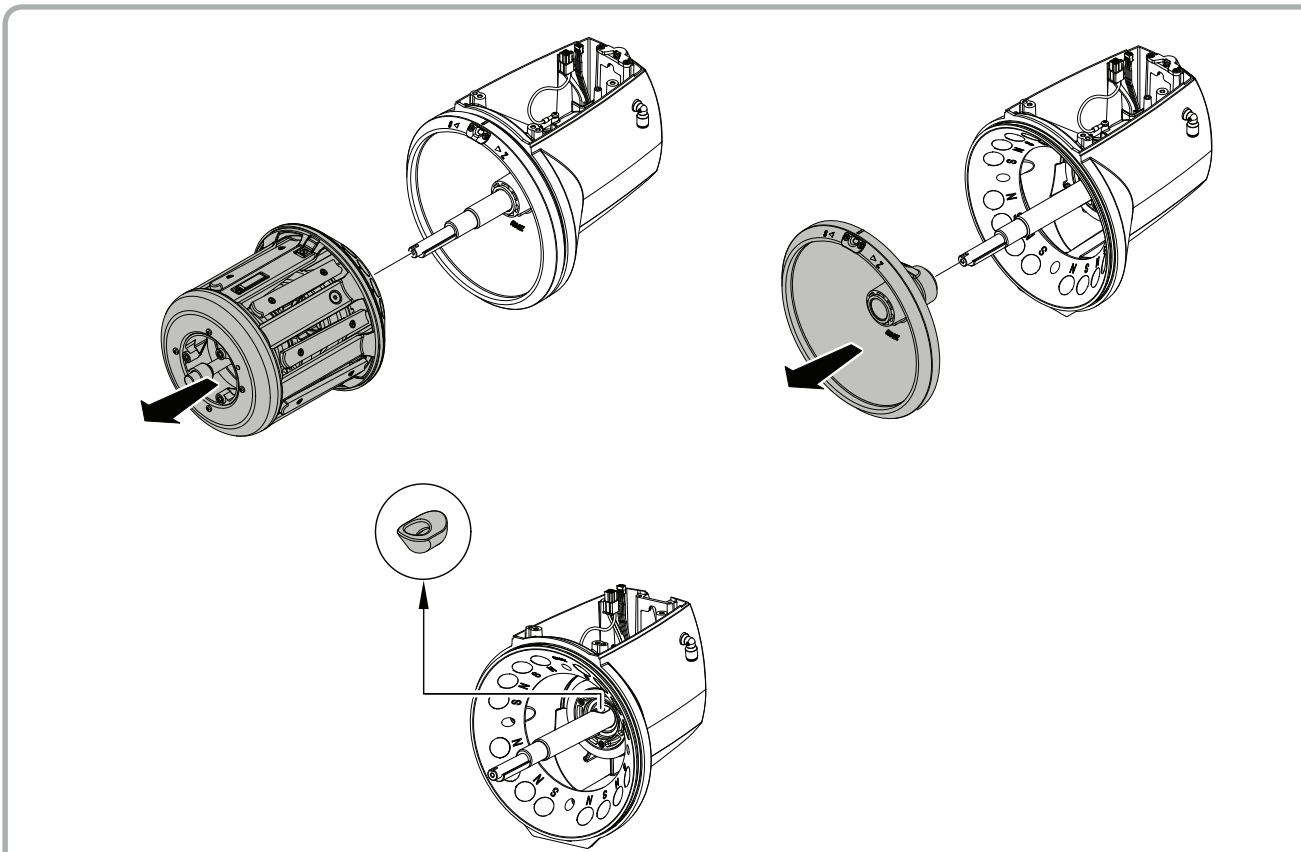

# 5 - MAINTENANCE AND COMPONENT REPLACEMENTS

Reflectors adjustments:

in the presence of yarns that leave residues on the reflectors (optical version), it is possible to mount them in a lower (front reflector) or rearward (rear reflector) position.

## FRONT REFLECTOR

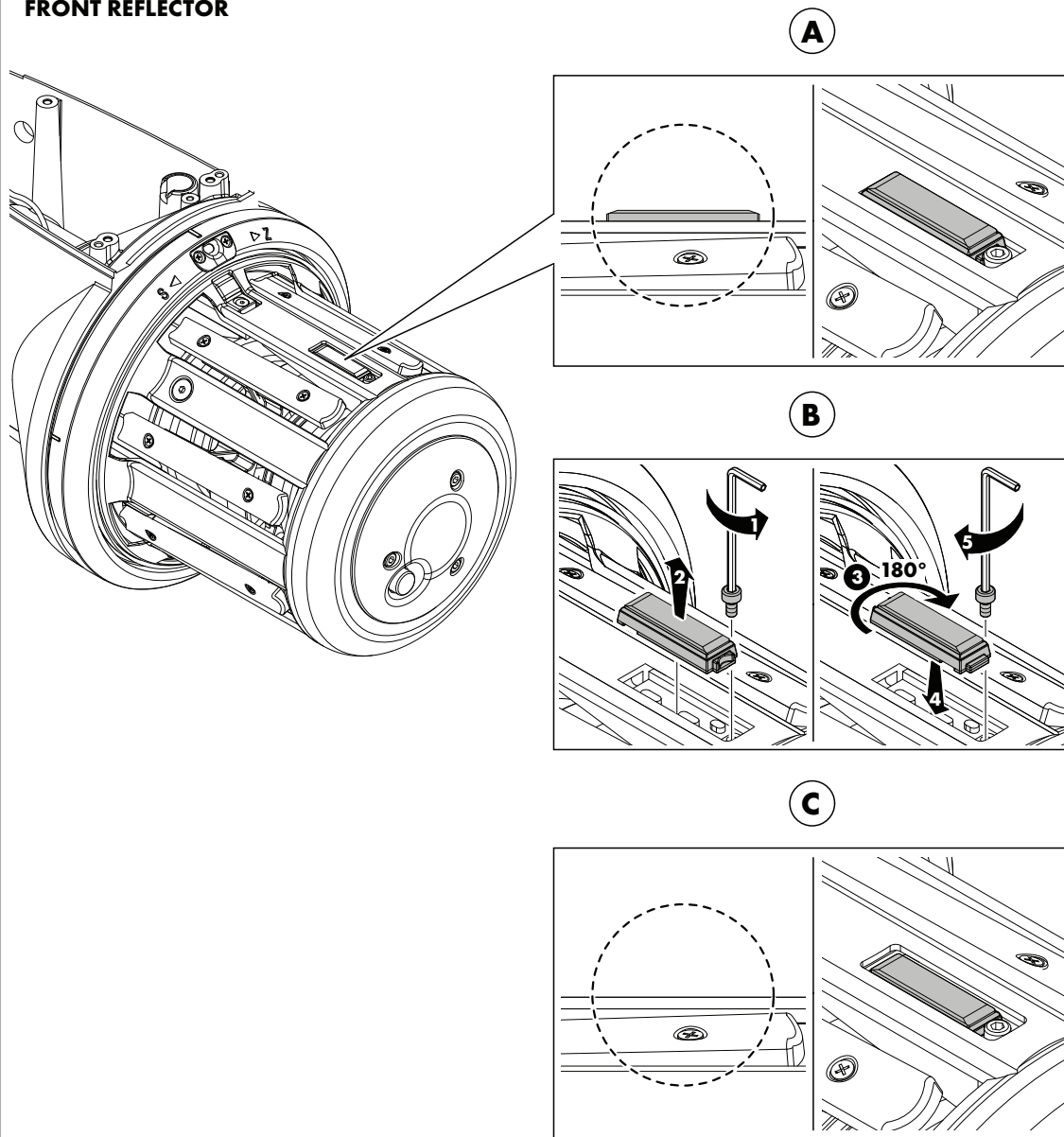

# 5 - MAINTENANCE AND COMPONENT REPLACEMENTS

## REAR REFLECTOR

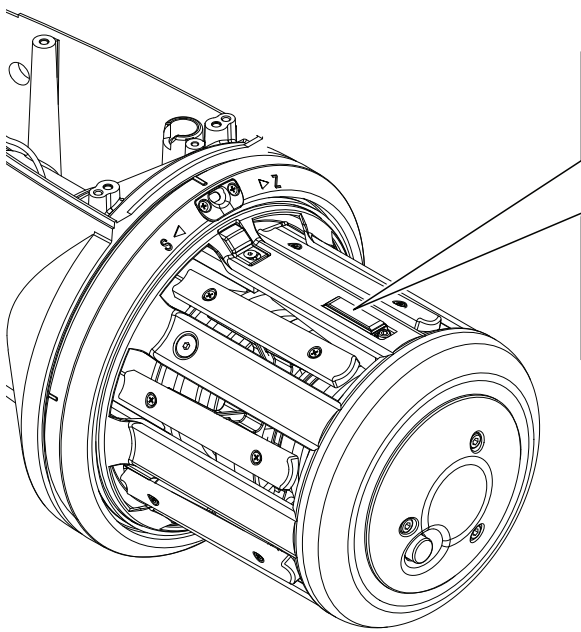

**A**

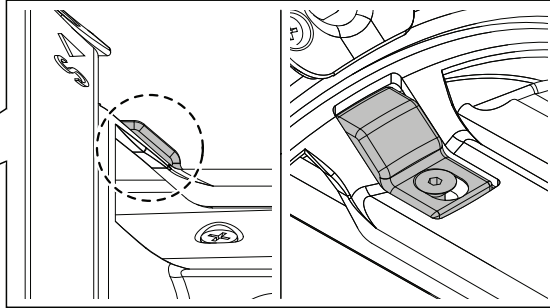

**B**

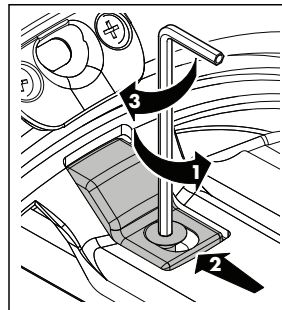

**C**

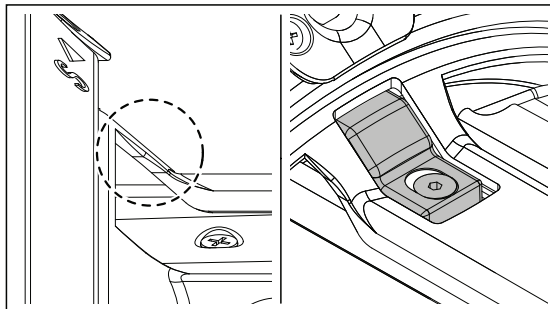

# 5 - MAINTENANCE AND COMPONENT REPLACEMENTS

## 5.1.2 REMOVING SINGLE PARTS OF SPOOL BODY

- 1) After removing the front drum cap, unscrew the central screw and remove the balancer. To reassemble the balancer, make sure to align it with the S / Z bushing of the flywheel as shown in the figure.

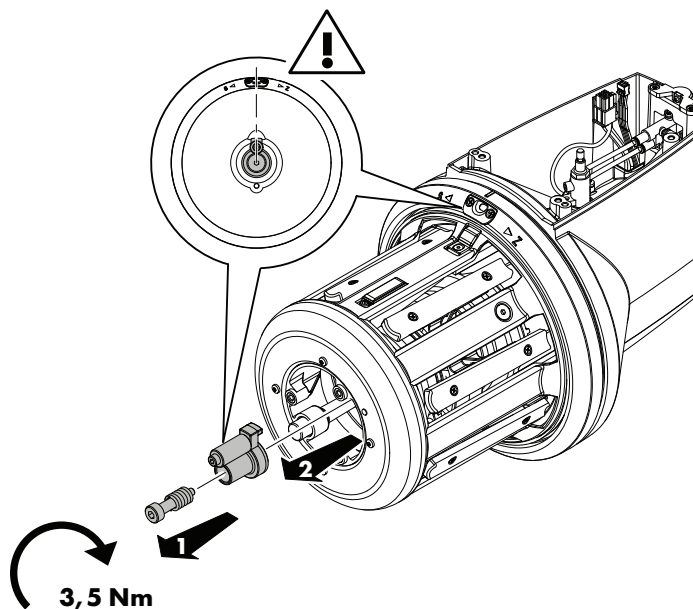

- 2) Remove the front drum reflector.

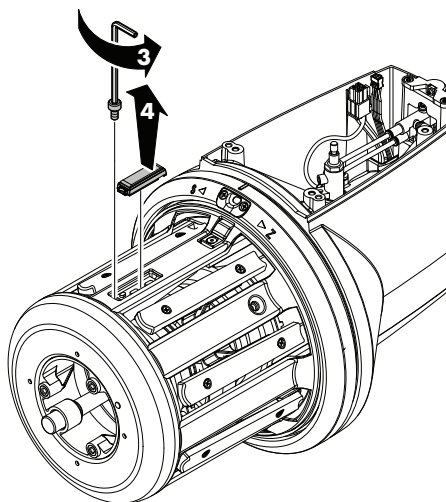

# 5 - MAINTENANCE AND COMPONENT REPLACEMENTS

3) Unscrew the 8 screws that fix the drum and remove it.

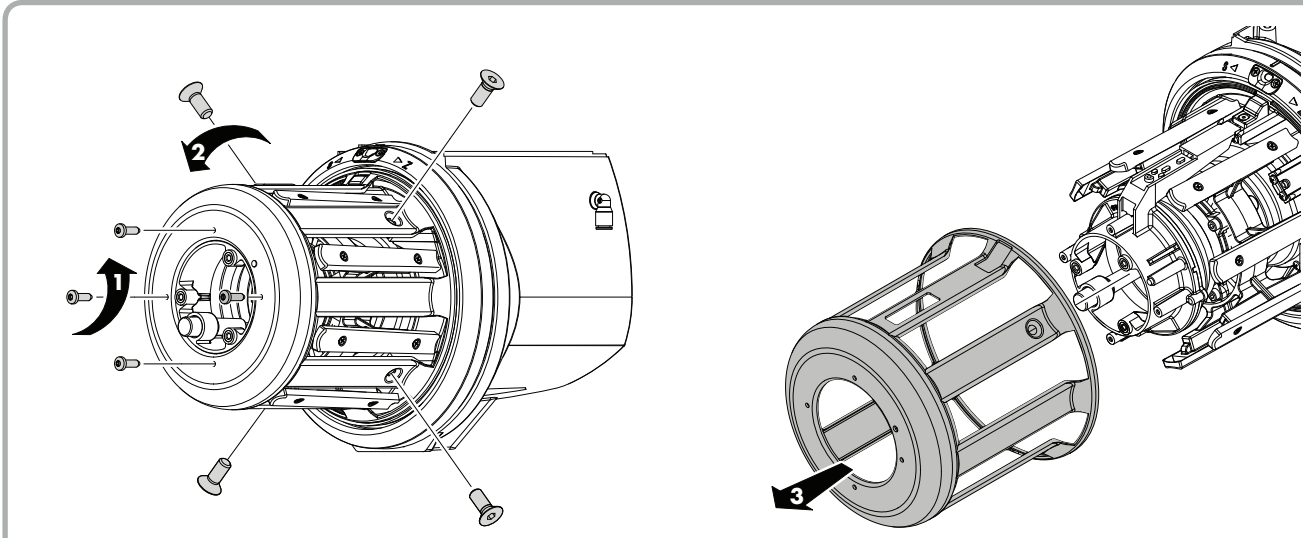

4) Unscrew the 4 screws of the front shock absorber unit and remove it.

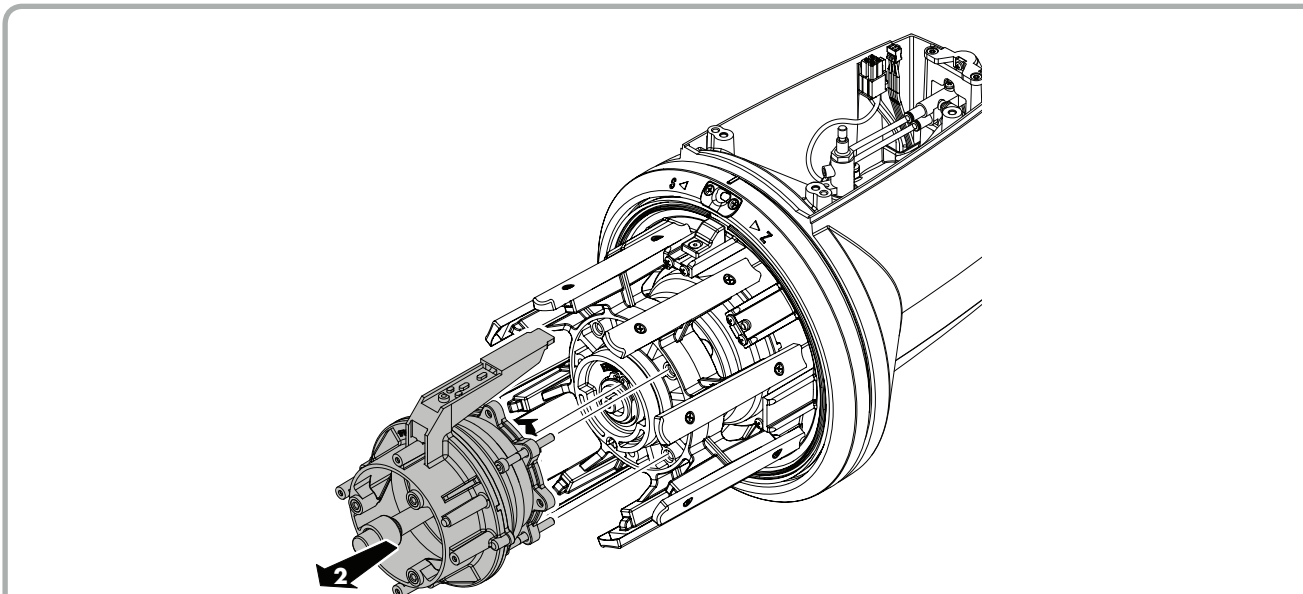

# 5 - MAINTENANCE AND COMPONENT REPLACEMENTS

5) It is now possible to remove the oscillating hub.

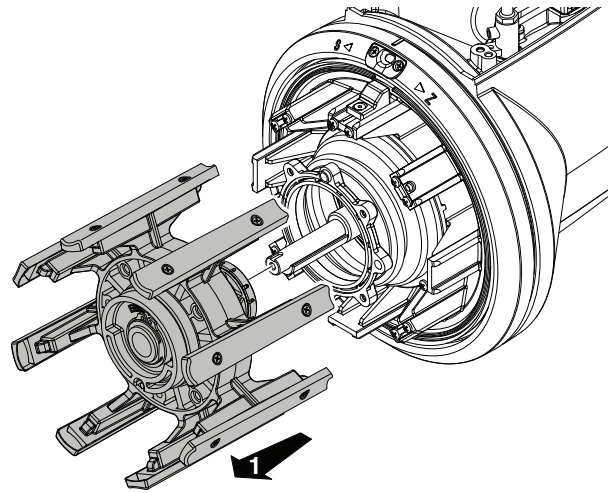

If necessary, it is also possible to extract the rear shock absorber and the magnet holder.

Pay attention when reassembling the oscillating hub to align the S / Z bushing with the bushing on the flywheel as shown in the picture. When inserting the oscillating hub, pay attention to align one of the screw seats without counterbore with the S / Z bushing of the flywheel as shown in the picture.

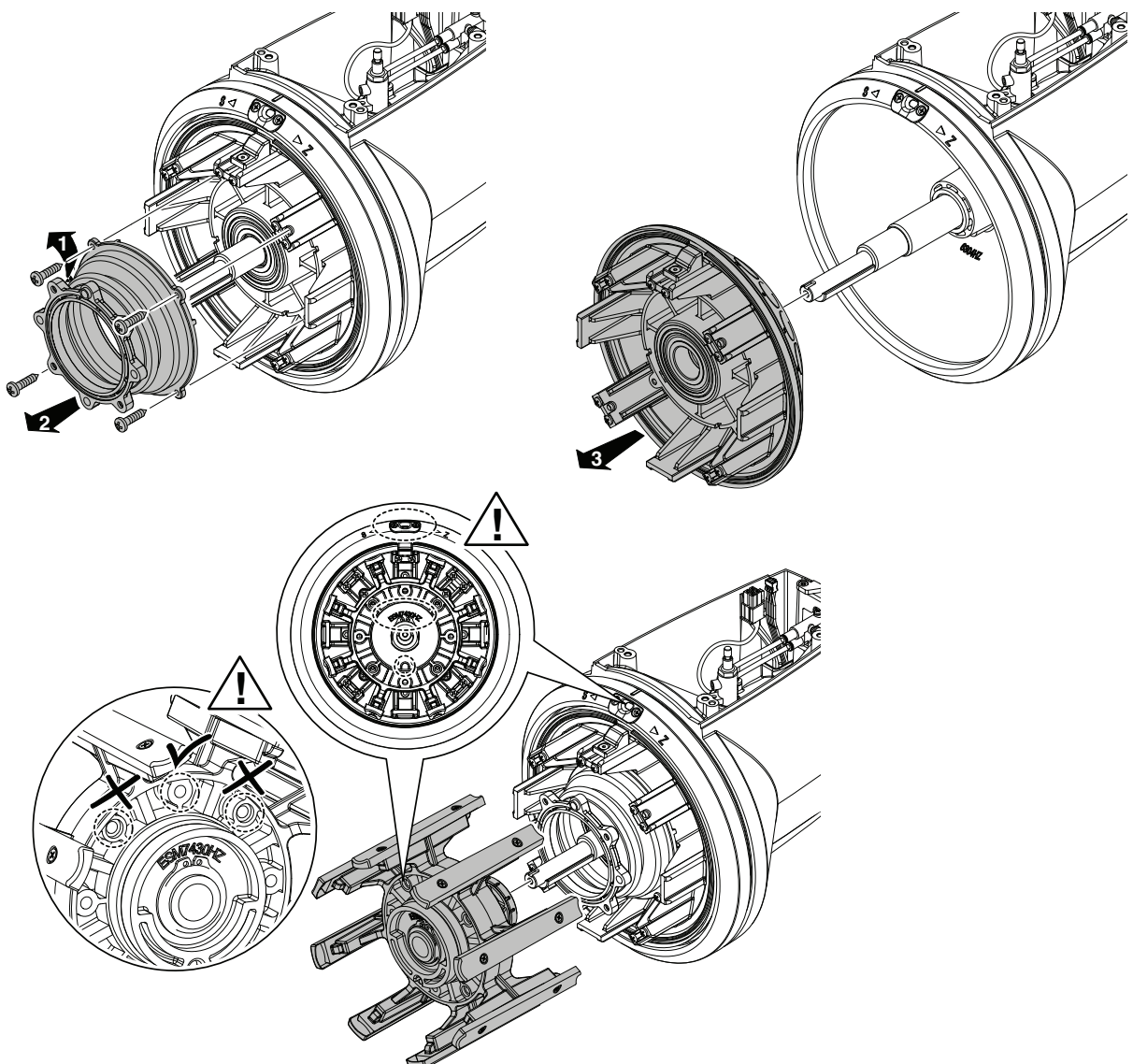

# 5 - MAINTENANCE AND COMPONENT REPLACEMENTS

## 5.2 REPLACEMENT OF THE ELECTRONIC CONTROL BOARD

To replace the electronic control board proceed as follows:

- 1) Turn off the yarn feeder by moving the **0 - I** switch to the **0** position



- 2) Turn off the power supply using the main switch on the textile machine.
- 3) Remove the power cable connector from the cover by unscrewing the 2 fixing screws.

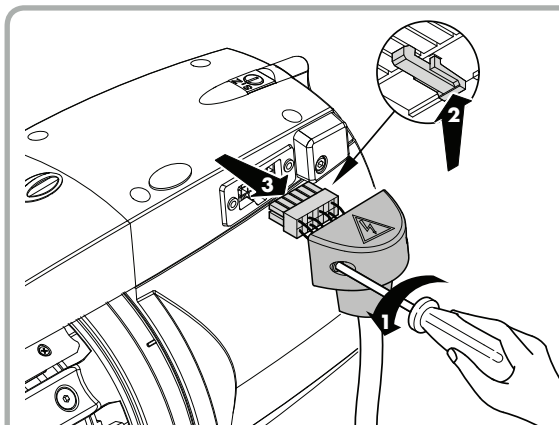

- 4) Unscrew the 4 screws (1), lift and remove the cover (2), releasing it from the cables and tubes coming from the body.

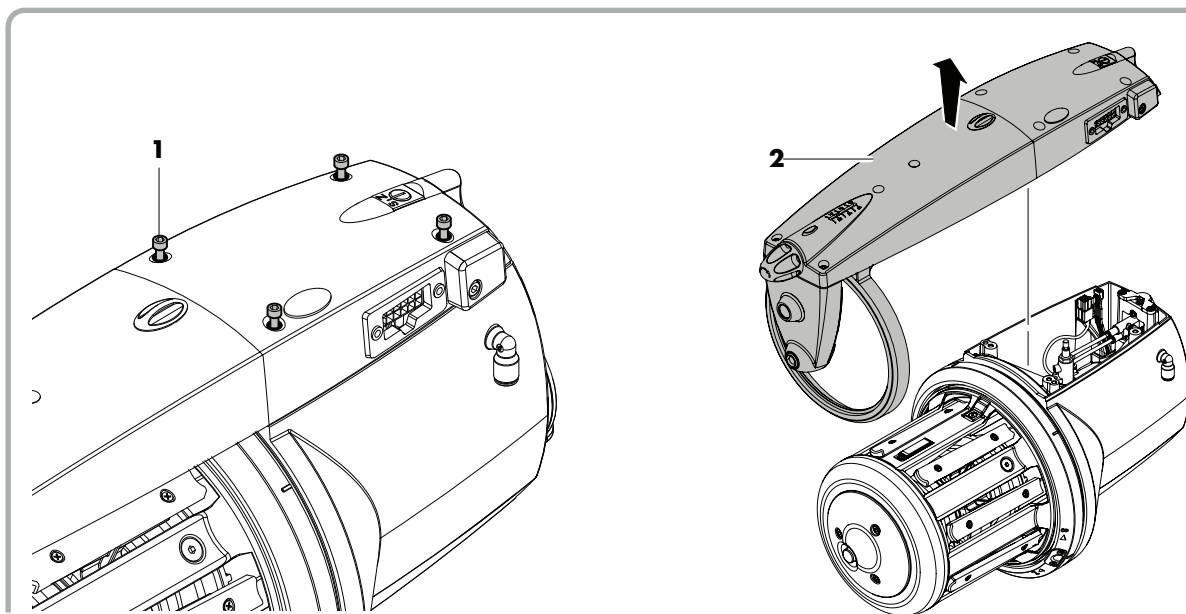

- 5) Unscrew the 9 screws and remove the electronic board. Place the new board in the housing and fix it using the relative screws.

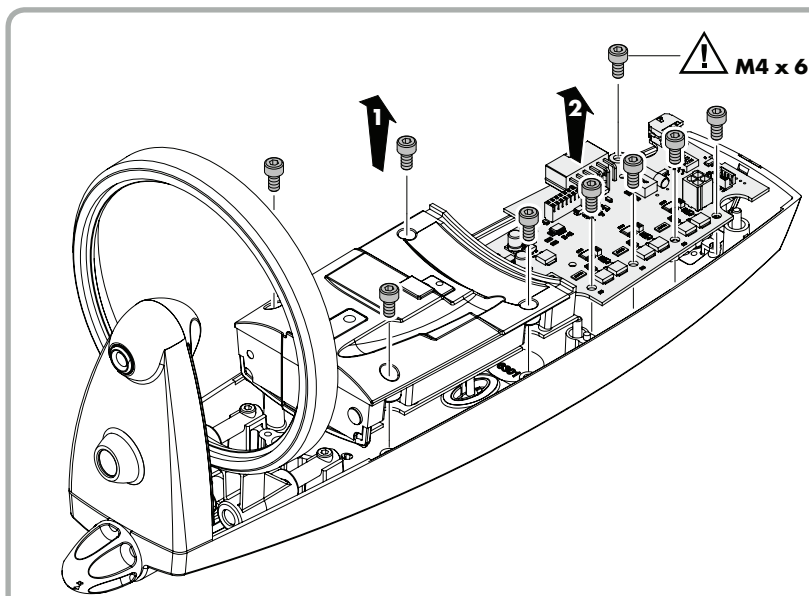

**NOTE:** After replacing the board, follow the procedure described in the next chapter to calibrate the motor and the photocells and adjust the position of the flywheel ceramic for pneumatic threading.

# 5 - MAINTENANCE AND COMPONENT REPLACEMENTS

## 5.3 OPTICAL VERSION: CALIBRATION OF MOTOR SENSORS, CALIBRATION OF OPTICAL SENSORS AND POSITIONING OF THE FLYWHEEL FOR PNEUMATIC THREADING

After replacing the main electronic board, the following calibration procedure must be executed:

**NOTE:** il Dip switch number 4 must be OFF.

### A. Feeder equipped with partial pneumatic threading or not equipped with pneumatic threading:

1. Remove the yarn from the feeder and turn it on with S-0-Z switch in position 0 (disabled alarms).
2. Leave main motor turn for 6-7 seconds. In this way the motor sensors parameters are correctly obtained.
3. Turn off the feeder. Set S-0-Z switch on S position and turn feeder on.  
The feeder will stop after a few turns due to yarn break alarm.
4. Move S-0-Z switch in sequence S-0-S-0-S-0 within 40 seconds from the beginning of the procedure. (at least 5 transitions must be executed).  
At the end of the movements, leave the switch in position 0.
5. Turn feeder off. At this point the calibration of the optical sensors takes place.  
If calibration goes to a good end, the light on the top cover blinks once.

**NOTE:** The blink has been introduced from software PRG9010.  
The previous software versions do not blink at the end of the calibration procedure.  
The feeder is now ready to be used (remember to set S-0-Z switch in position S or Z).

### B. Feeder equipped with total pneumatic threading: Sensors calibration and flywheel positioning.

1. Remove the yarn from the feeder and turn it on with S-0-Z switch in position 0 (disabled alarms).
2. Leave main motor turn for 6-7 seconds. In this way the motor sensors parameters are correctly obtained.
3. Turn off the feeder. Set S-0-Z switch on Z position and turn feeder on.  
The feeder will stop after a few turns due to yarn break alarm. The flywheel will move to have its ceramic in position for pneumatic threading. The flywheel is not free to move but it keeps this position.  
If this position allows to thread yarn correctly by air (see picture), go to point 7.  
On the contrary if this position is not correct, it must be modified, go to point 4.
4. Move S-0-Z switch in sequence Z-0-Z-0-Z-0-Z within 40 seconds from the beginning of the procedure. (at least 5 transitions must be executed).  
At the end of the movements, leave the switch in position Z.

## 5 - MAINTENANCE AND COMPONENT REPLACEMENTS

- At this point the feeder sets the flywheel free to move.  
To set the correct position, insert the weft taker into the feeder letting it come out of the flywheel in correspondence of the slit placed under the top cover (see picture).

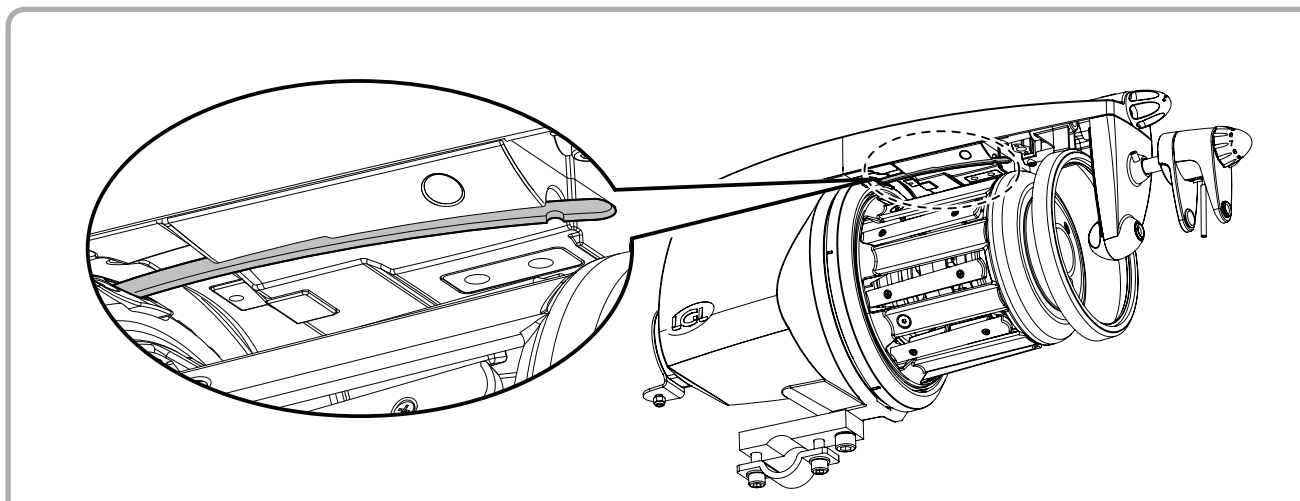

- When the flywheel is correctly positioned, turn feeder off and the position will be stored for Z rotation.
- Turn off the feeder. Set S-O-Z switch on S position and turn feeder on.  
The feeder will stop after a few turns due to yarn break alarm. The flywheel will move to have its ceramic in position for pneumatic threading. The flywheel is not free to move but it keeps this position.
- Move S-O-Z switch in sequence S-O-S-O-S-O within 40 seconds from the beginning of the procedure. (at least 5 transitions must be executed).  
At the end of the movements, leave the switch in position O.
- At this point the feeder sets the flywheel free to move. In case it is necessary to set the position of the flywheel for pneumatic threading, insert the weft taker into the feeder letting it come out of the flywheel in correspondence of the slit placed under the top cover (see picture).
- When the flywheel is correctly positioned, turn feeder off and the position will be stored for S rotation. In addition the feeder executes calibration of optical sensors.  
If calibration goes to a good end, the light on the top cover blinks once.

**NOTA:** il lampeggio viene emesso dalla versione software PRG9010.

Le versioni software precedenti non emettono lampeggio.

L'alimentatore è ora pronto per l'uso (ricordare di mettere il selettore S-O-Z in posizione S oppure Z secondo necessità).

# 5 - MAINTENANCE AND COMPONENT REPLACEMENTS

## 5.4 MECHANICAL VERSION: CALIBRATION OF MOTOR SENSORS AND POSITIONING OF THE FLYWHEEL FOR PNEUMATIC THREADING

After replacing the main electronic board, the following calibration procedure must be executed:

**NOTE:** il Dip switch number 4 must be OFF.

### A. Feeder equipped with partial pneumatic threading or not equipped with pneumatic threading:

1. Remove the yarn from the feeder and turn it on with S-0-Z switch in position 0 (disabled alarms).
2. Leave main motor turn for 6-7 seconds. In this way the motor sensors parameters are correctly obtained.

**NOTE:** the weft feeder is now ready for use (remember to set the S-0-Z switch to the S or Z position as required).

### B. Feeder equipped with total pneumatic threading: Sensors calibration and flywheel positioning.

1. Remove the yarn from the feeder and turn it on with S-0-Z switch in position 0 (disabled alarms).
2. Leave main motor turn for 6-7 seconds. In this way the motor sensors parameters are correctly obtained.
3. Turn off the feeder. Set S-0-Z switch on Z position and turn feeder on.  
The feeder will stop after a few turns due to yarn break alarm. The flywheel will move to have its ceramic in position for pneumatic threading. The flywheel is not free to move but it keeps this position.  
If this position allows to thread yarn correctly by air (see picture), go to point 7.  
On the contrary if this position is not correct, it must be modified, go to point 4.
4. Move S-0-Z switch in sequence Z-0-Z-0-Z-0-Z within 40 seconds from the beginning of the procedure. (at least 5 transitions must be executed).  
At the end of the movements, leave the switch in position Z.
5. At this point the feeder sets the flywheel free to move.  
To set the correct position, insert the weft taker into the feeder letting it come out of the flywheel in correspondence of the slit placed under the top cover (see picture).

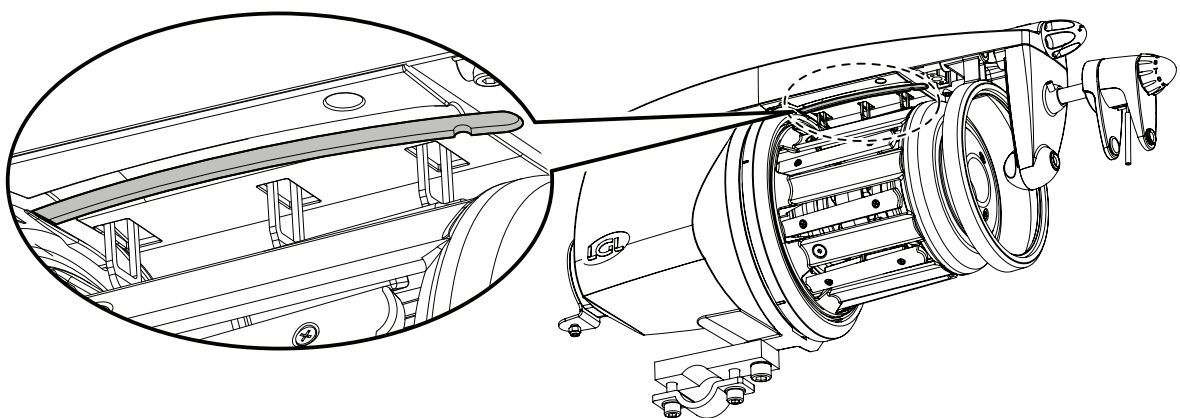

## 5 - MAINTENANCE AND COMPONENT REPLACEMENTS

6. When the flywheel is correctly positioned, turn feeder off and the position will be stored for Z rotation.
7. Turn off the feeder. Set S-0-Z switch on S position and turn feeder on.  
The feeder will stop after a few turns due to yarn break alarm. The flywheel will move to have its ceramic in position for pneumatic threading. The flywheel is not free to move but it keeps this position.
8. Move S-0-Z switch in sequence S-0-S-0-S-0 within 40 seconds from the beginning of the procedure. (at least 5 transitions must be executed).  
At the end of the movements, leave the switch in position 0.
9. At this point the feeder sets the flywheel free to move. In case it is necessary to set the position of the flywheel for pneumatic threading, insert the weft taker into the feeder letting it come out of the flywheel in correspondence of the slit placed under the top cover (see picture).
10. When the flywheel is correctly positioned, switch off the power supply and this will save the desired position for S-rotation.

**NOTE:** the weft feeder is now ready for use (remember to set the S-0-Z switch to the S or Z position as required).

# 6 - MOUNTING THE TENSIONERS

## 6.1 MOUNTING THE TWM TENSION MODULATOR

To mount the TWM tension modulator with its kit, follow these steps:

- 1) Release the tensioner carriage by pressing the release push-button (F), then fix the anti-ballooning ring into the special seat that is found in the top panel.

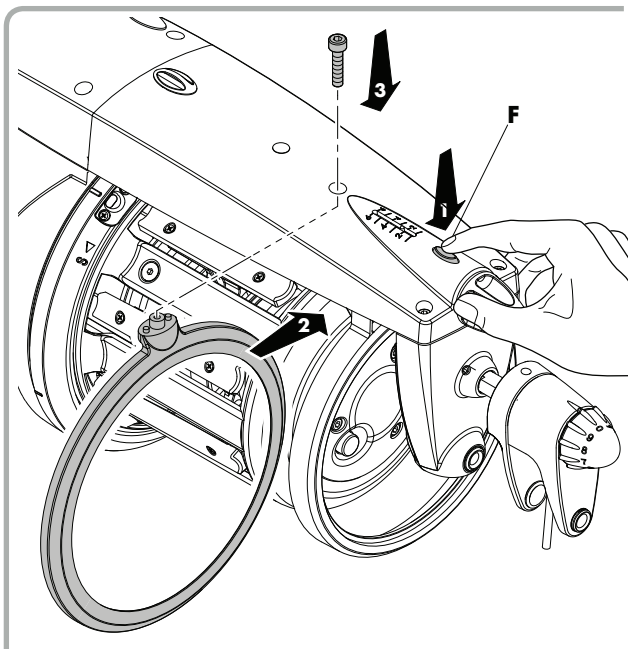

- 2) Insert the TWM tension modulator on the movable stand.

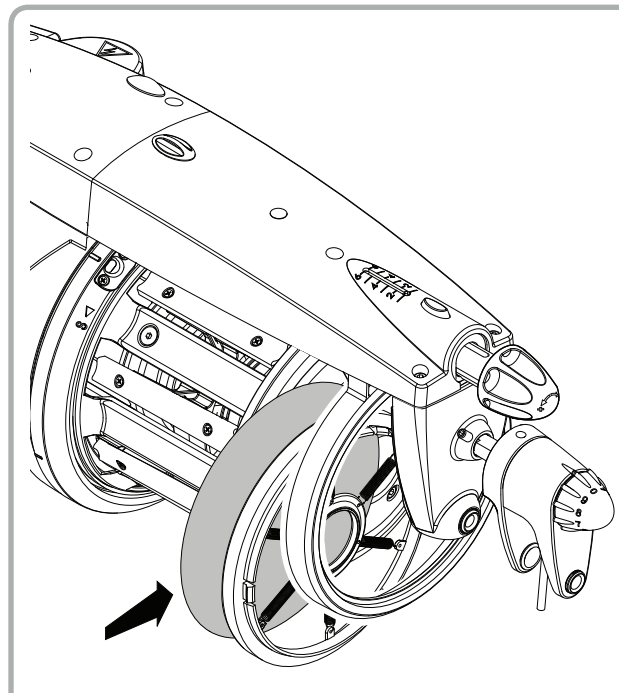

- 3) Engage the tensioner carriage again by pressing knob (G).

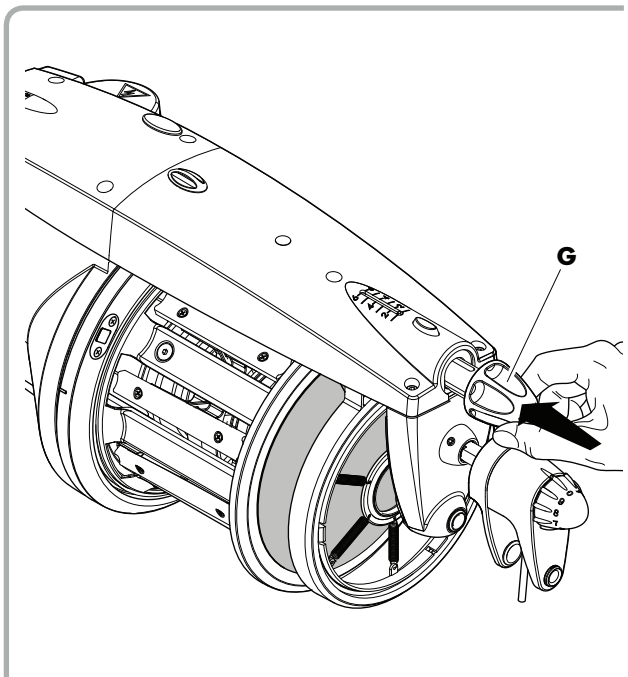

- 4) After threading the accumulator and winding the weft around the weft spool body, adjust the tensioning as indicated in the figure.

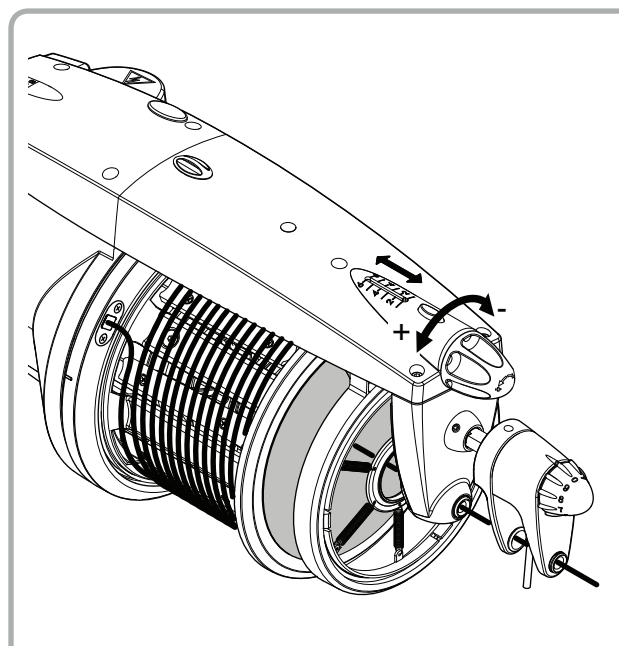

Refer to the applications field to obtain the desired tensioning.

# 6 - MOUNTING THE TENSIONERS

## 6.2 MOUNTING THE BRISTLE BRUSH

To mount the bristle brush with its kit, follow these steps:

1) Release the tensioner carriage by acting on the release push-button (F).

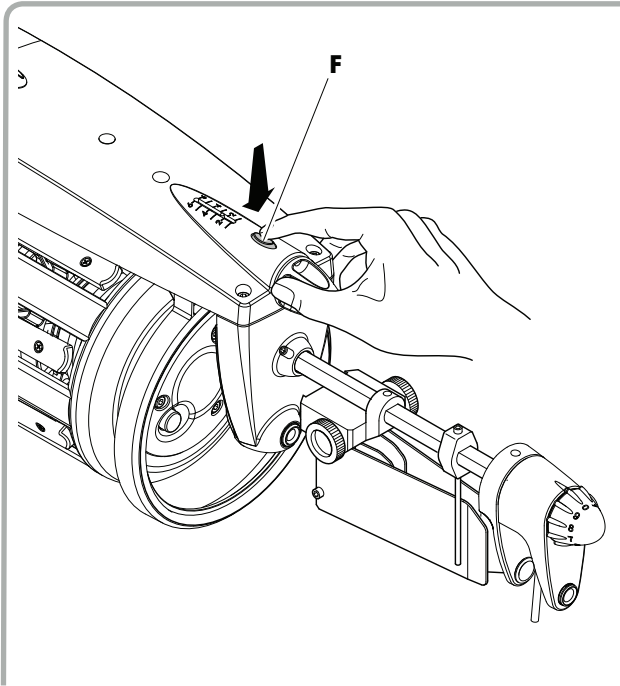

2) Insert brush holder (O) and then brush (P) on the movable stand.

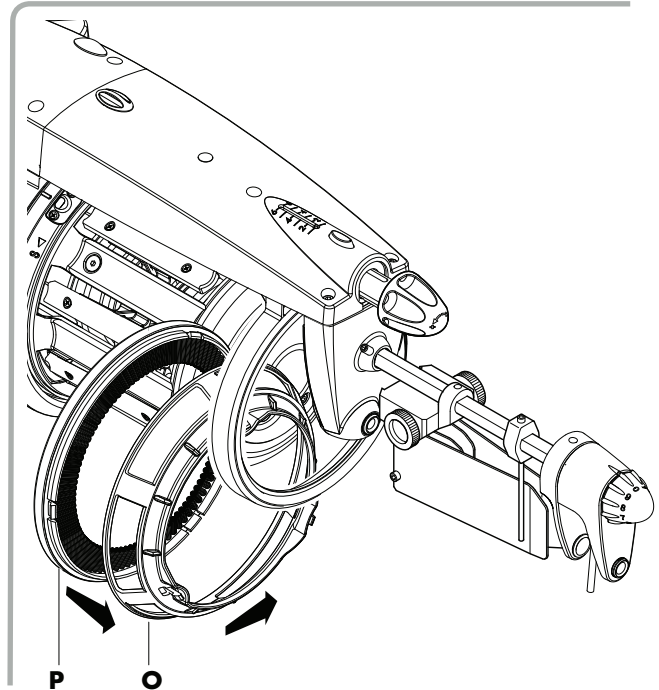

3) Engage the tensioner carriage again by pressing knob (G).

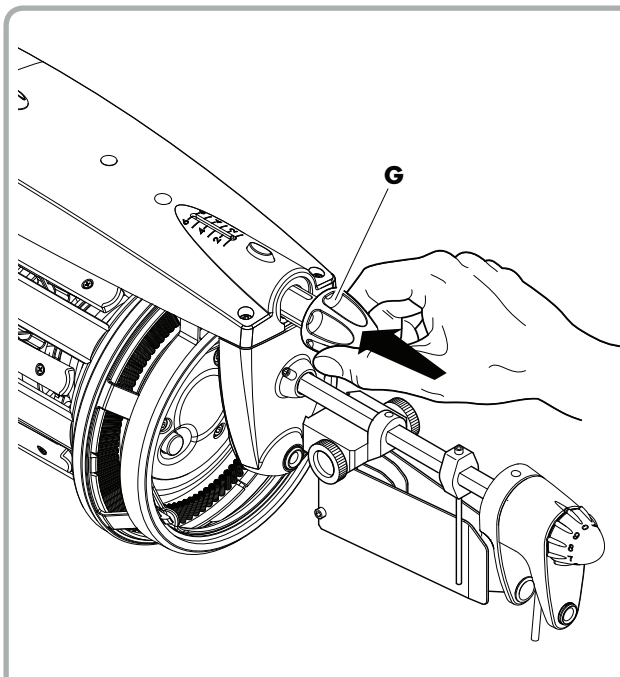

4) After threading the weft feeder and winding the weft around the weft spool body, adjust the tensioning as indicated in the figure.

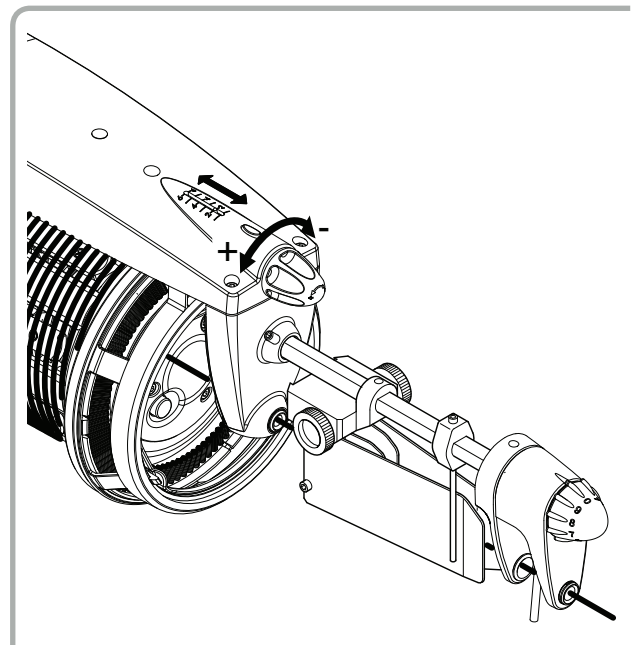

# 6 - MOUNTING THE TENSIONERS

## 6.3 MOUNTING THE METAL BRUSH

**N.B.:** it is recommended to change the outlet bracket to facilitate the mounting of the metal brush kit.

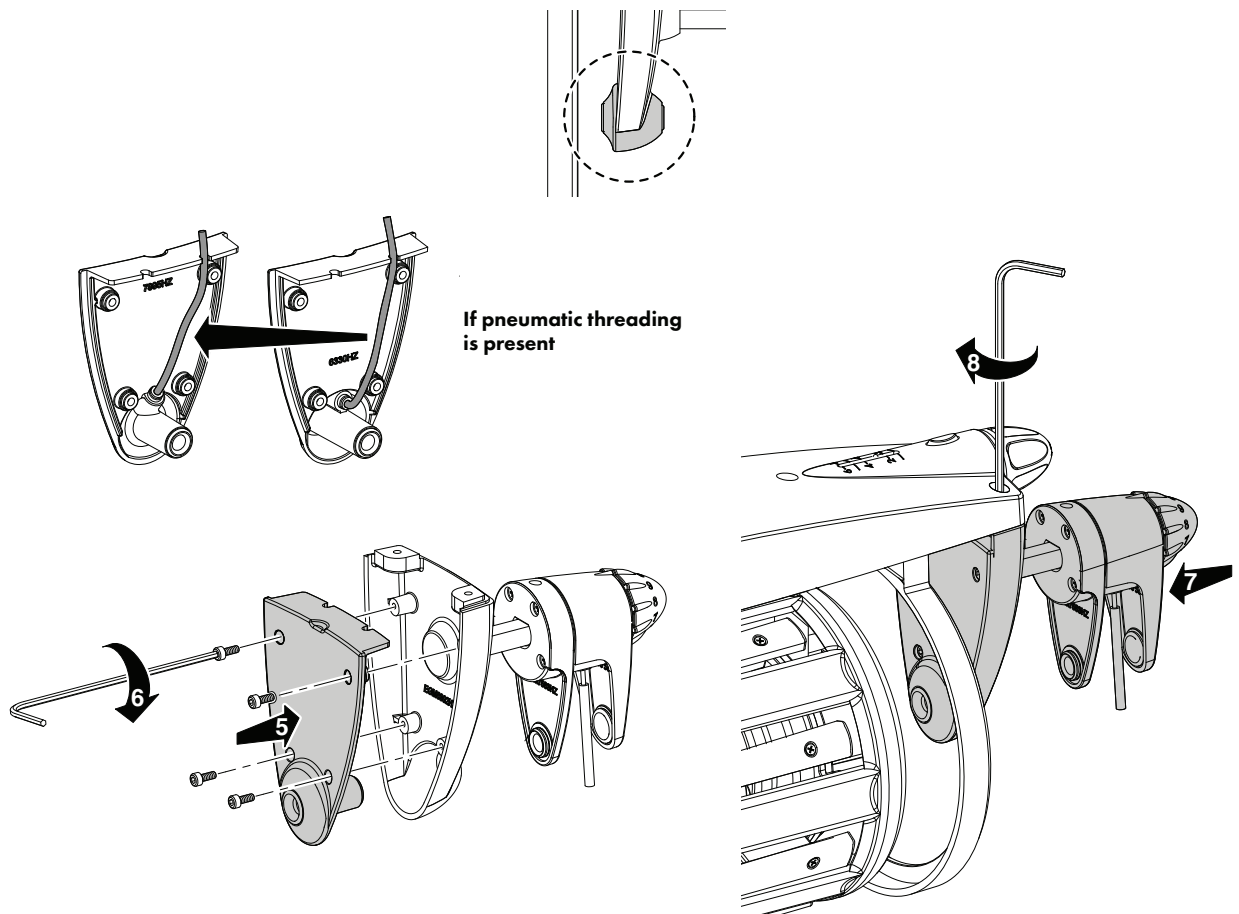
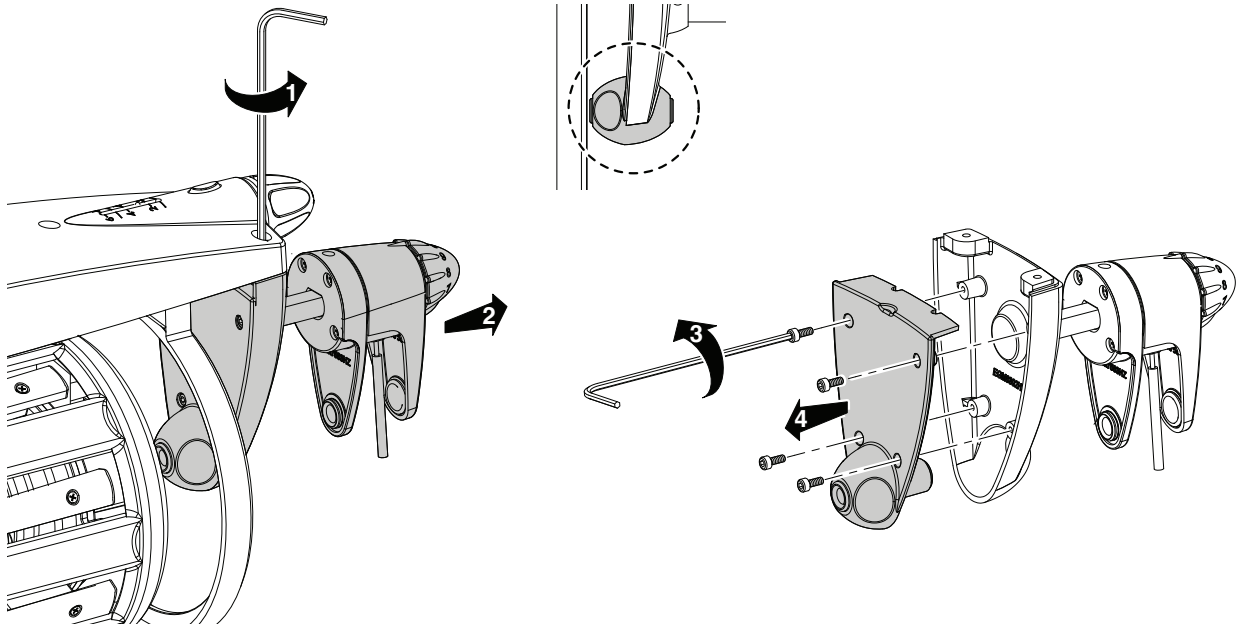

## 6 - MOUNTING THE TENSIONERS

To mount the metal brush with the related kit, take the following actions:

1) Release the tensioner carriage by pressing the release push-button (F).

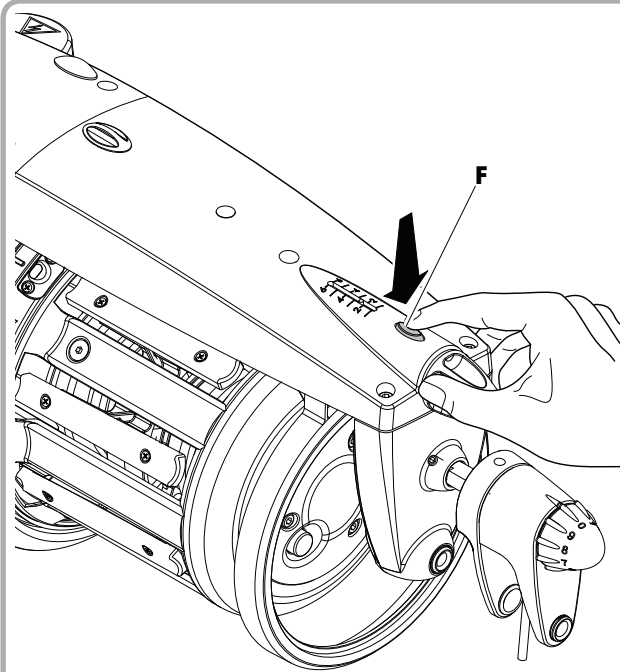

2) Insert the metal brush into the dedicated support and fasten it in place.

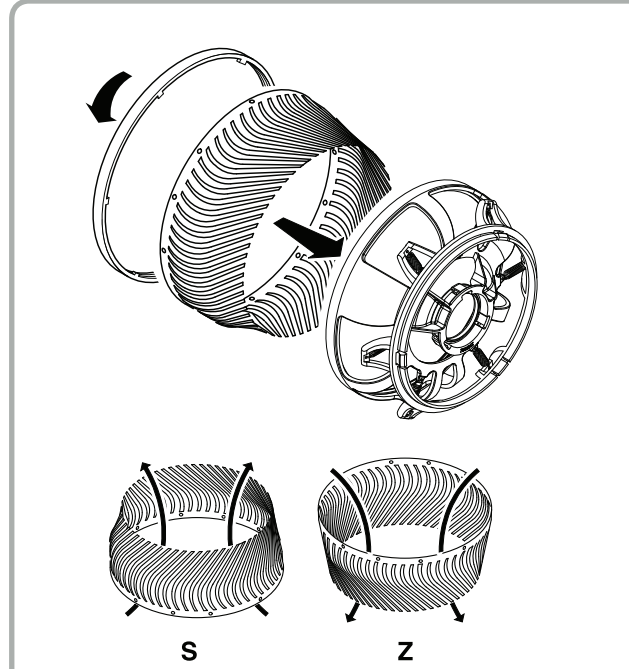

3) Lock the support into the brake holding ring.

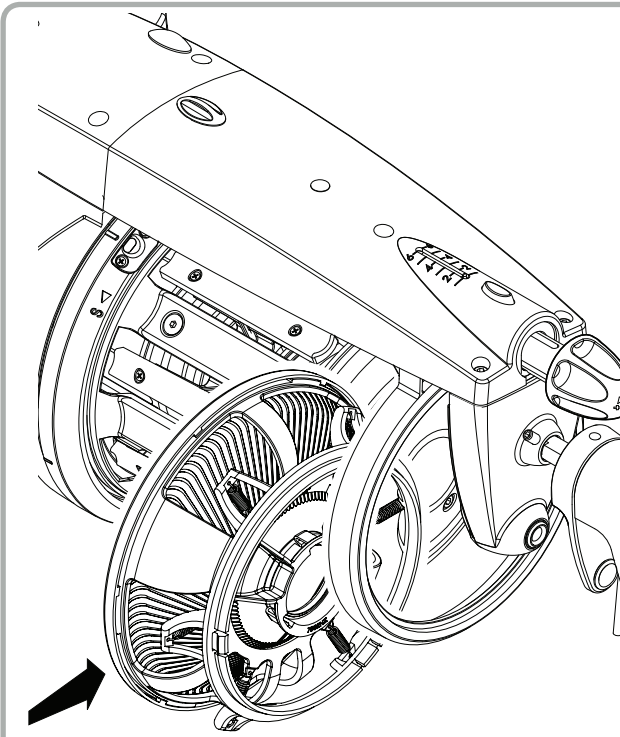

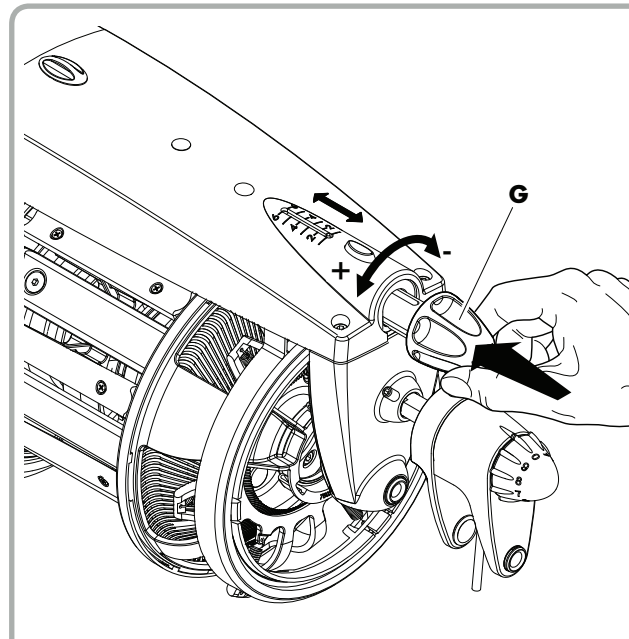

4) Lock the braking carriage once again by pressing hand-knob (G). After inserting the feeder and winding the weft round the spool body, adjust the braking as shown in the figure.

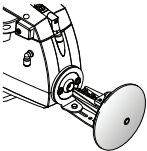
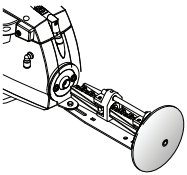
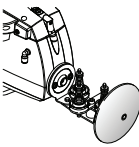
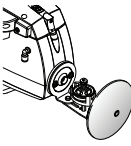
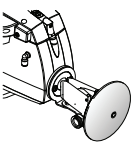
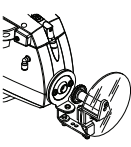
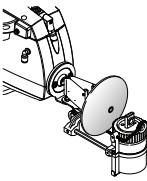

# 7 - APPLICATION FIELD FOR TENSIONERS

## 7.1 APPLICATION FIELD FOR INPUT TENSIONERS

WEFT TYPE	Wool yarn	Cotton and viscose staple fibre	Strong twisted yarns, crêpe and silk yarns	Stiff yarns: Linen, Camel hair, etc.	Viscose, Synthetic fibres
Compensator tensioner 	from Nm 12 to Nm 120	from Nm 8 to Nm 200	from Nm 15 to Nm 150	from Nm 3 to Nm 90	from Nm 9 to Nm 200
Double compensator tensioner 			from Nm 15 to Nm 150		from Nm 48 to Nm 200
Disk tensioner 	from Nm 12 to Nm 30		from Nm 15 to Nm 120		from Nm 15 to Nm 120
Disk tensioner for pneumatic threading 	from Nm 12 to Nm 120	from Nm 8 to Nm 200	from Nm 15 to Nm 120	from Nm 6 to Nm 90	from Nm 90 to Nm 120
Leaf tensioner 	from Nm 12 to Nm 30	from Nm 8 to Nm 40		from Nm 3 to Nm 50	from Nm 9 to Nm 50
Anti-snarling unit 	from Nm 20 to Nm 120	from Nm 20 to Nm 120	from Nm 15 to Nm 150		from Nm 40 to Nm 150
Oiling unit 	from Nm 8 to Nm 120	from Nm 8 to Nm 200	from Nm 15 to Nm 150	from Nm 3 to Nm 90	from Nm 9 to Nm 200
Waxing unit 	from Nm 8 to Nm 30	from Nm 8 to Nm 60	from Nm 15 to Nm 70	from Nm 3 to Nm 40	from Nm 9 to Nm 80

# 7 - APPLICATION FIELD FOR TENSIONERS

## 7.2 APPLICATION FIELD FOR THE "TWM" TENSION MODULATOR

STD.

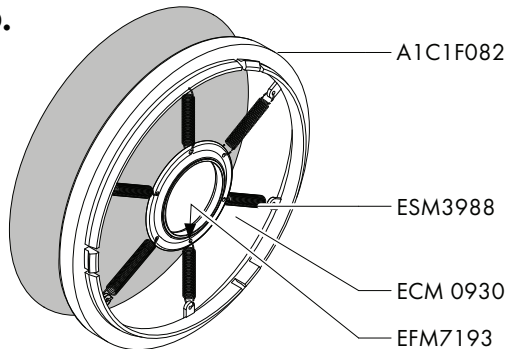

Ø 80

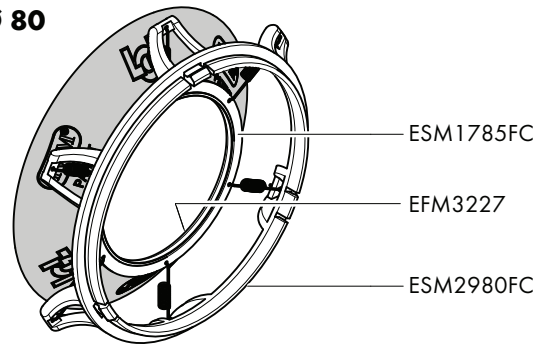

### TWM type KL (code A1N2SA347KL02P)

Spring fitting option	Wool yarn	Cotton and viscose staple fibre	Strong twisted yarns, crêpe and silk yarns	Stiff yarns: linen, camel hair, etc.	Viscose, synthetic fibres
 <p><b>Standard fitting</b> n° 6 springs ø 0,4 22mm in length</p>	from Nm 40 to Nm 80	beyond Nm 85	from Nm 70 to Nm 200	beyond Nm 50	from Nm 80 to Nm 150

Springs supplied: no. 6 springs ø 0,4 mm - 22 mm in length - ELM 1629

**N.B.:** The spool body trunk is transparent

### TWM type LT05 (code A1C4S774LT05PR)

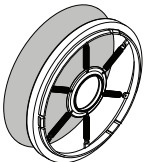
Spring fitting option	Wool yarn	Cotton and viscose staple fibre	Strong twisted yarns, crêpe and silk yarns	Stiff yarns: linen, camel hair, etc.	Viscose, synthetic fibres
 <p><b>Standard fitting</b> no.3 springs ø 0,7 33 mm in length no.3 springs ø 0,4 22 mm in length</p>	from Nm 40 to Nm 60	from Nm 50 to Nm 110	from Nm 45 to Nm 80	from Nm 25 to Nm 50	from Nm 45 to Nm 90

Springs supplied: no. 3 springs ø 0,7 mm - 33 mm in length - ELM 2269  
no. 6 springs ø 0,4 mm - 22 mm in length - ELM 1629

In cases when lower tensions are required, use only no. 6 springs ø 0,4 mm - 22 mm in length - ELM 1629.

# 7 - APPLICATION FIELD FOR TENSIONERS

## TWM type LT10 (code A1C4S774LT10PR)

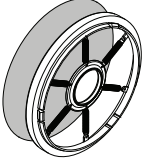
Spring fitting option	Wool yarn	Cotton and viscose staple fibre	Strong twisted yarns, crêpe and silk yarns	Stiff yarns: linen, hemp, camel hair, jute, etc.	Viscose, synthetic fibres
 <p><b>Standard fitting</b> no.3 springs ø 0,7 33 mm in length n° 3 springs ø 0,4 22 mm in length</p>	from Nm 15 to Nm 50	from Nm 30 to Nm 85	from Nm 30 to Nm 70	from Nm 25 to Nm 70	from Nm 25 to Nm 90
<p><b>Option 2</b> no.3 springs ø 0,7 22 mm in length no.3 springs ø 0,7 33 mm in length</p>	from Nm 5 to Nm 15	from Nm 8 to Nm 20		For greater counts, we suggest using T.W.M. type "R-R"	For greater counts, we suggest using T.W.M. type "R-R"

Springs supplied: no. 3 springs ø 0,7 mm - 33 mm in length - ELM 2269  
no. 3 springs ø 0,7 mm - 22 mm in length - ELM 1630  
no. 6 springs ø 0,4 mm - 22 mm in length - ELM 1629

The 6 springs that are 4 mm in ø ELM1629 shall be fitted in cases when lower tensions are required.

## TWM type RR-80 (code A1C4S774RR0080)

Spring fitting option	Wool yarn	Cotton and viscose staple fibre	Stiff yarns: linen, hemp, camel hair, jute, etc.	Viscose, synthetic fibres
 <p><b>Standard fitting</b> no.6 springs ø 0,7 22 mm in length</p>	from Nm 1 to Nm 8	from Nm 1 to Nm 20	from Nm 1 to Nm 18	from Nm 1 to Nm 20

Springs supplied: no. 6 springs ø 0,7 mm - 22 mm in length - ELM 1630

## TWM type KR20 (code A1N3SA016 - 4KR20)

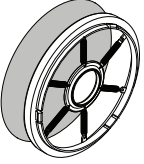
Spring fitting option	Wool yarn	Cotton and viscose staple fibre	Strong twisted yarns, crêpe and silk yarns	Stiff yarns: linen, camel hair, etc.	Viscose, synthetic fibres
 <p><b>Standard fitting</b> no.6 springs ø 0,4 22 mm in length</p>	from Nm 50 to Nm 100	from Nm 50 to Nm 200	beyond Nm 50	beyond Nm 50	from Nm 50 to Nm 150

Springs supplied: no. 6 springs ø 0,4 mm - 22 mm in length - ELM 1629

# 7 - APPLICATION FIELD FOR TENSIONERS

## TWM type KR40 (code A1N3SA016 - 7KR40)

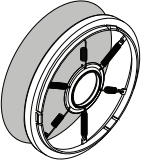
Spring fitting option	Wool yarn	Cotton and viscose staple fibre	Strong twisted yarns, crêpe and silk yarns	Stiff yarns: linen, hemp, camel hair, jute, etc.	Viscose, synthetic fibres
 <p><b>Standard fitting</b> no.3 springs ø 0,7 33 mm in length n° 3 springs ø 0,4 22 mm in length</p>	from Nm 15 to Nm 50	from Nm 20 to Nm 50	from Nm 20 to Nm 50	from Nm 30 to Nm 50	from Nm 20 to Nm 50

Springs supplied: no. 3 springs ø 0,7 mm - 33 mm in length - ELM 2269  
no. 3 springs ø 0,7 mm - 22 mm in length - ELM 1630  
no. 6 springs ø 0,4 mm - 22 mm in length - ELM 1629

The 6 springs that are 4 mm in ø ELM1629 shall be fitted in cases when lower tensions are required.

## TWM type PE20 (code A1N3S994 - 04PE20)

Spring fitting option	Wool yarn	Cotton and viscose staple fibre	Strong twisted yarns, crêpe and silk yarns	Stiff yarns: linen, camel hair, etc.	Viscose, synthetic fibres
 <p><b>Standard fitting</b> n° 6 springs ø 0,4 22mm in length</p>	from Nm 50 to Nm 100	from Nm 50 to Nm 200	beyond Nm 50	beyond Nm 50	from Nm 50 to Nm 150

Springs supplied: no. 6 springs ø 0,4 mm - 22 mm in length - ELM 1629

## TWM type PE40 (code A1N3S994 - 74PE40)

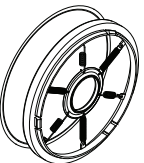
Spring fitting option	Wool yarn	Cotton and viscose staple fibre	Strong twisted yarns, crêpe and silk yarns	Stiff yarns: linen, hemp, camel hair, jute, etc.	Viscose, synthetic fibres
 <p><b>Standard fitting</b> no.3 springs ø 0,7 33 mm in length n° 3 springs ø 0,4 22 mm in length</p>	from Nm 15 to Nm 50	from Nm 20 to Nm 50	from Nm 20 to Nm 50	from Nm 30 to Nm 50	from Nm 20 to Nm 50

Springs supplied: no. 3 springs ø 0,7 mm - 33 mm in length - ELM 2269  
no. 3 springs ø 0,7 mm - 22 mm in length - ELM 1630  
no. 6 springs ø 0,4 mm - 22 mm in length - ELM 1629

The 6 springs that are 4 mm in ø ELM1629 shall be fitted in cases when lower tensions are required.

The TWM is not recommended for weaving lamé strip.

The use of oil and paraffin causes tension on the yarn to decrease: when working in these conditions, increase the TWM tension.

# 7 - APPLICATION FIELD FOR TENSIONERS

## 7.3 APPLICATION FIELD FOR BRISTLE BRUSH TENSIONERS

WEFT TYPE	Wool yarn	Cotton and viscose staple fibre	Strong twisted yarns, crêpe and silk yarns	Stiff yarns: linen, camel hair, etc.	Viscose, synthetic fibres
<b>Goat hair</b> (white)	over Nm 30	over Nm 60	over Nm 60	over Nm 30	over Nm 60
<b>Chinese mane</b> (brown)	from Nm 18 to Nm 60	from Nm 45 to Nm 90	from Nm 50 to Nm 90	from Nm 16 to Nm 40	from Nm 45 to Nm 80
<b>0,20</b> (black)	from Nm 10 to Nm 20	from Nm 20 to Nm 50	from Nm 36 to Nm 60	from Nm 10 to Nm 30	from Nm 18 to Nm 60
<b>0,30</b> (black)	from Nm 1 to Nm 12	from Nm 1 to Nm 30	from Nm 15 to Nm 40	from Nm 6 to Nm 18	from Nm 9 to Nm 20

**Note:** radial versions are considered as being in the same application range, but performance tend to a harder model.

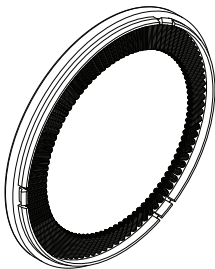

BRISTLE BRUSHES		
BRISTLE TYPE	Code "S" TWIST	Code "Z" TWIST
<b>0,20</b>	A1C1F211-T	A1C1F213-T
<b>0,30</b>	A1C1F210-T	A1C1F212-T
<b>Chinese mane</b>	A1C1F214-T	A1C1F215-T
<b>Goat hair</b>	A1C1F216-T	A1C1F217-T
<b>Radial goat hair</b>	A1C1F231-T	
<b>0,2 Radial</b>	A1C1F222-T	
<b>0,3 Radial</b>	A1C1F229-T	
<b>Radial Chinese mane</b>	A1C1F223-T	

As regards the **Goat Hair** type and the **Chinese Maine** type brushes, we suggest you use output tensioner device: **2 Medium Lamella Leaf Tensioners** or, as an alternative, **Standard Leaf Tensioner**.

As regards brush type **0,20** and brush type **0,30**, we suggest using the output tensioner device: **Standard Leaf Tensioner** or, as an alternative, **2 leaf tensioners with folded lamella**.

The **Standard Leaf Tensioner + Folded Lamella Leaf Tensioner** or **1 Leaf Tensioner with medium Lamella kits** are also available.

# 7 - APPLICATION FIELD FOR TENSIONERS

## 7.4 APPLICATION FIELD FOR METAL BRUSH TENSIONERS

WEFT TYPE	Wool yarn	Cotton and viscose staple fibre	Strong twisted yarns, crêpe and silk yarns	Stiff yarns: linen, camel hair, etc.	Viscose, synthetic fibres
<b>Type E 10</b> (Thickness 0,10 mm)	over Nm 45	from Nm 60 to Nm 200	oltre Nm 90	from Nm 40 to Nm 90	oltre Nm 100
<b>Type E 15</b> (Thickness 0,15 mm)	from Nm 25 to Nm 50	from Nm 30 to Nm 70	from Nm 25 to Nm 90	from Nm 30 to Nm 50	from Nm 25 to Nm 90
<b>Type E 20</b> (Thickness 0,20 mm)	from Nm 12 to Nm 30	from Nm 18 to Nm 34	from Nm 12 to Nm 40	from Nm 18 to Nm 45	from Nm 9 to Nm 40
<b>Type F 10</b> (Thickness 0,10 mm)	from Nm 25 to Nm 50	from Nm 30 to Nm 70	from Nm 25 to Nm 90	from Nm 30 to Nm 50	from Nm 25 to Nm 90
<b>Type F 15</b> (Thickness 0,15 mm)	from Nm 12 to Nm 30	from Nm 18 to Nm 34	from Nm 12 to Nm 40	from Nm 18 to Nm 45	from Nm 9 to Nm 40
<b>Type F 20</b> (Thickness 0,20 mm)	from Nm 1 to Nm 15	from Nm 1 to Nm 20	from Nm 1 to Nm 15	from Nm 1 to Nm 20	from Nm 2 to Nm 10



METAL BRUSHES		
TYPE	CODE	SHAPE
<b>Type E 10</b>	EFM6375-10	
<b>Type E 15</b>	EFM6375-15	
<b>Type E 20</b>	EFM6375-20	
<b>Type F 10</b>	EFM6376-10	
<b>Type F 15</b>	EFM6376-15	
<b>Type F 20</b>	EFM6376-20	

# 7 - APPLICATION FIELD FOR TENSIONERS

## 7.5 YARN COUNT SYSTEMS CONVERSION TABLE

Nm	Ne	tex	den	Dtex	Ne <sub>L</sub>	Nm	Ne	tex	den	Dtex	Ne <sub>L</sub>
6.048	3,571	170	-	-	<b>10</b>	<b>36.000</b>	21,26	28	<b>250</b>	<b>280</b>	59,53
7.257	4,286	140	-	-	<b>12</b>	36.290	21,43	28	248	275	<b>60</b>
<b>8.000</b>	4,724	125	-	-	13,23	39.310	23,21	<b>25</b>	229	254	<b>65</b>
8.467	<b>5</b>	<b>120</b>	-	-	<b>14</b>	<b>40.000</b>	23,62	<b>25</b>	225	<b>250</b>	66,14
<b>9.000</b>	5,315	110	<b>1000</b>	<b>1100</b>	14,88	40.640	<b>24</b>	<b>25</b>	221	246	67,20
9.676	5,714	105	930	1033	<b>16</b>	42.330	25	24	212	235	<b>70</b>
<b>10.000</b>	5,905	<b>100</b>	<b>900</b>	<b>1000</b>	16,54	44.030	<b>26</b>	<b>23</b>	204	227	72,80
10.160	<b>6</b>	<b>100</b>	866	984	16,80	<b>45.000</b>	26,57	22	<b>200</b>	<b>220</b>	74,41
10.890	6,429	92	827	918	<b>18</b>	47.410	<b>28</b>	<b>21</b>	189	210	78,40
<b>12.000</b>	7,086	84	<b>750</b>	830	19,84	<b>48.000</b>	28,35	<b>21</b>	187	208	79,37
12.100	7,143	84	744	826	<b>20</b>	48.380	28,57	<b>21</b>	186	206	<b>80</b>
13.300	7,857	76	676	751	<b>22</b>	<b>50.000</b>	29,53	<b>20</b>	<b>180</b>	200	82,68
13.550	<b>8</b>	<b>72</b>	664	738	22,40	50.800	<b>30</b>	<b>20</b>	177	197	84
<b>15.000</b>	8,858	68	<b>600</b>	<b>660</b>	24,80	54.190	<b>32</b>	<b>18</b>	166	184	89,6
15.120	8,929	68	595	661	<b>25</b>	54.430	32,14	<b>18</b>	165	183	<b>90</b>
<b>16.000</b>	9,449	64	560	620	26,46	<b>60.000</b>	35,43	17	<b>150</b>	<b>167</b>	99,21
16.930	<b>10</b>	<b>60</b>	<b>530</b>	590	<b>28</b>	60.480	35,71	17	149	166	<b>100</b>
<b>18.000</b>	10,63	56	<b>500</b>	550	29,76	60.960	<b>36</b>	<b>16</b>	147	165	100,8
18.140	10,71	56	496	551	<b>30</b>	64.350	38	<b>16</b>	140	156	106,4
19.350	11,43	52	465	516	<b>32</b>	67.730	<b>40</b>	<b>15</b>	132	147	112
<b>20.000</b>	11,81	<b>50</b>	<b>450</b>	<b>500</b>	33,07	<b>70.000</b>	41,34	14	129	143	115,7
20.320	<b>12</b>	<b>50</b>	443	492	33,60	74.510	<b>44</b>	<b>13</b>	121	134	123,2
21.170	12,50	48	425	472	<b>35</b>	75.000	44,29	<b>13</b>	<b>120</b>	<b>133</b>	124
22.500	13,29	44	<b>400</b>	440	37,20	<b>80.000</b>	47,24	<b>12,5</b>	112	125	132,3
23.710	<b>14</b>	<b>42</b>	380	420	39,20	81.280	<b>48</b>	<b>12,5</b>	110	122	134,4
24.190	14,29	42	372	413	<b>40</b>	84.670	<b>50</b>	<b>12</b>	106	118	<b>140</b>
25.710	15,19	38	<b>350</b>	390	42,52	<b>90.000</b>	53,15	11	<b>100</b>	<b>110</b>	148,8
27.090	<b>16</b>	<b>36</b>	332	369	44,80	101.600	<b>60</b>	<b>10</b>	88	97	168
27.210	16,07	<b>36</b>	331	367	<b>45</b>	118.500	<b>70</b>	<b>8,4</b>	76	<b>84</b>	196
<b>30.000</b>	17,72	34	<b>300</b>	<b>335</b>	49,61	<b>120.000</b>	70,86	<b>8,4</b>	<b>75</b>	<b>84</b>	198,4
30.240	17,86	34	297	330	<b>50</b>	135.500	<b>80</b>	<b>7,2</b>	66	73	224
30.480	<b>18</b>	<b>32</b>	295	328	50,40	<b>150.000</b>	88,58	6,8	<b>60</b>	<b>67</b>	248
<b>32.000</b>	18,90	<b>32</b>	280	310	52,91	152.400	<b>90</b>	<b>6,4</b>	59	64	252
33.260	19,64	<b>30</b>	270	300	<b>55</b>	169.300	<b>100</b>	<b>6</b>	53	58	<b>280</b>
33.870	<b>20</b>	<b>30</b>	266	295	56	186.300	<b>110</b>	<b>5,2</b>	<b>48</b>	53	-
<b>34.000</b>	20,08	<b>30</b>	265	294	56,22	203.200	<b>120</b>	<b>5</b>	<b>44</b>	49	-

# 8 - TENS AND SRAKE WITH DISPLAY FOR WEAVING MACHINES

Software from ELBR1736 (tens) and ELBR1836 (Srake)

## Main screen

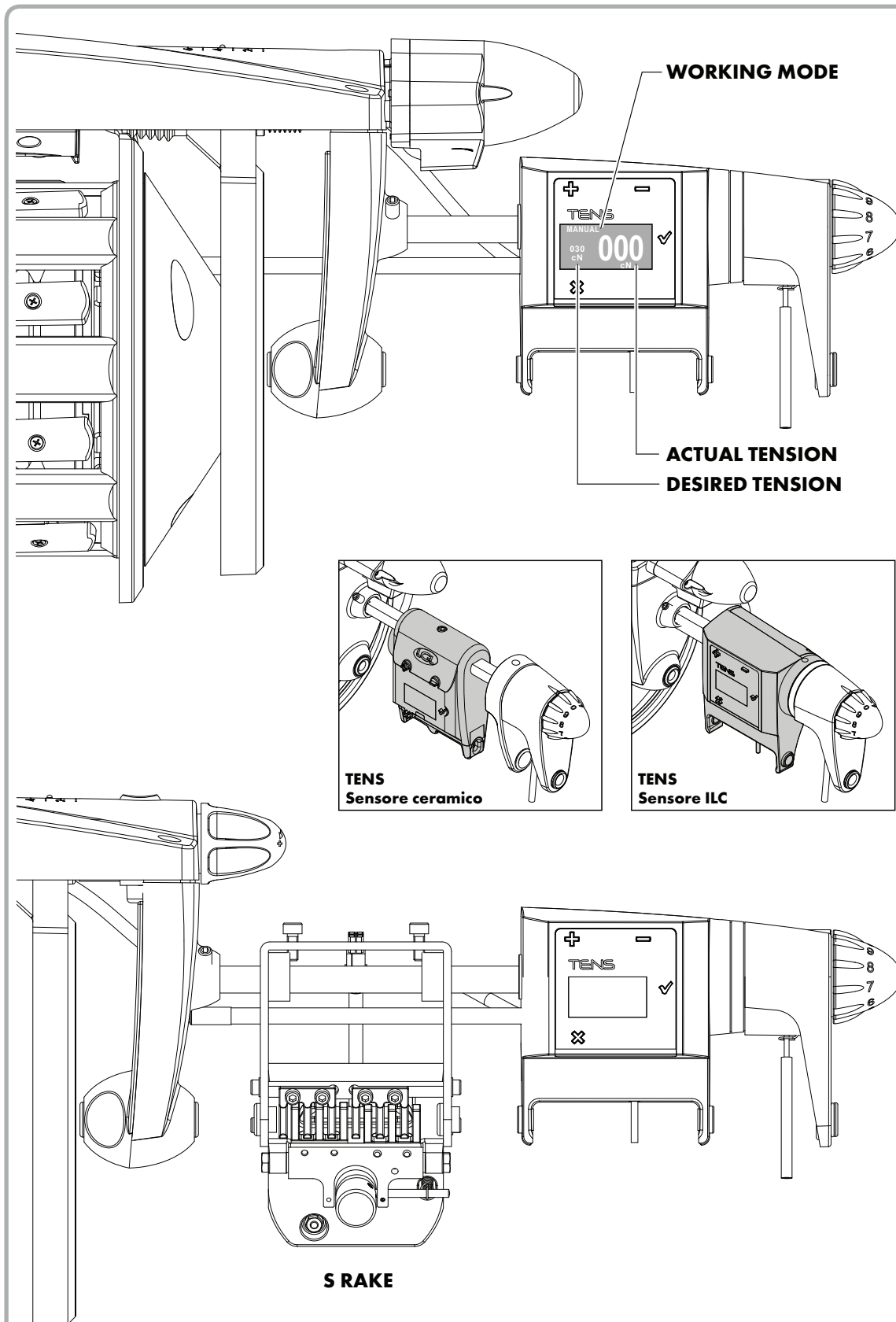

# 8 - TENS AND SRAKE WITH DISPLAY FOR WEAVING MACHINES

Software from ELBR1736 (tens) and ELBR1836 (Srake)

## 8.1 INTRODUCTION

The Tens device sets and adjusts the average yarn tension on the weft during the insertion.

The front light located under the TENS writing in the picture defines the different status of the device.

When the light is ON, the device is in manual mode. If the light is ON and the loom is running, the average tension is not adjusted and the Tens brake does not move.

When the light is OFF, the device is in automatic mode. If the light is OFF and the loom is running, the tension is adjusted and this is the normal working condition. In this condition by acting on +/- buttons it is possible to increase or decrease the yarn tension.

The display shows in the main screen the information about actual tension (big ) and the desired tension (small), and the working mode MANUAL or AUTOMATIC. Moreover if the writing RUN appears, it means that the weaving machine is working. The RUN writings disappears if the loom stops.

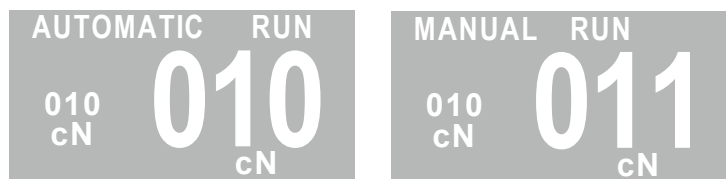

## 8.2 BEFORE STARTING

- Proceed with threading using the plastic weft taker supplied with the feeder (do not use metal weft takers)
- The measuring pin has a maximum range of just a few tenths of a mm. Pay particular attention not to overload it by applying manual pressure.
- Start the OFFSET procedure after the sensor has reached the weaving room temperature and 5 minutes after the sensor was started.

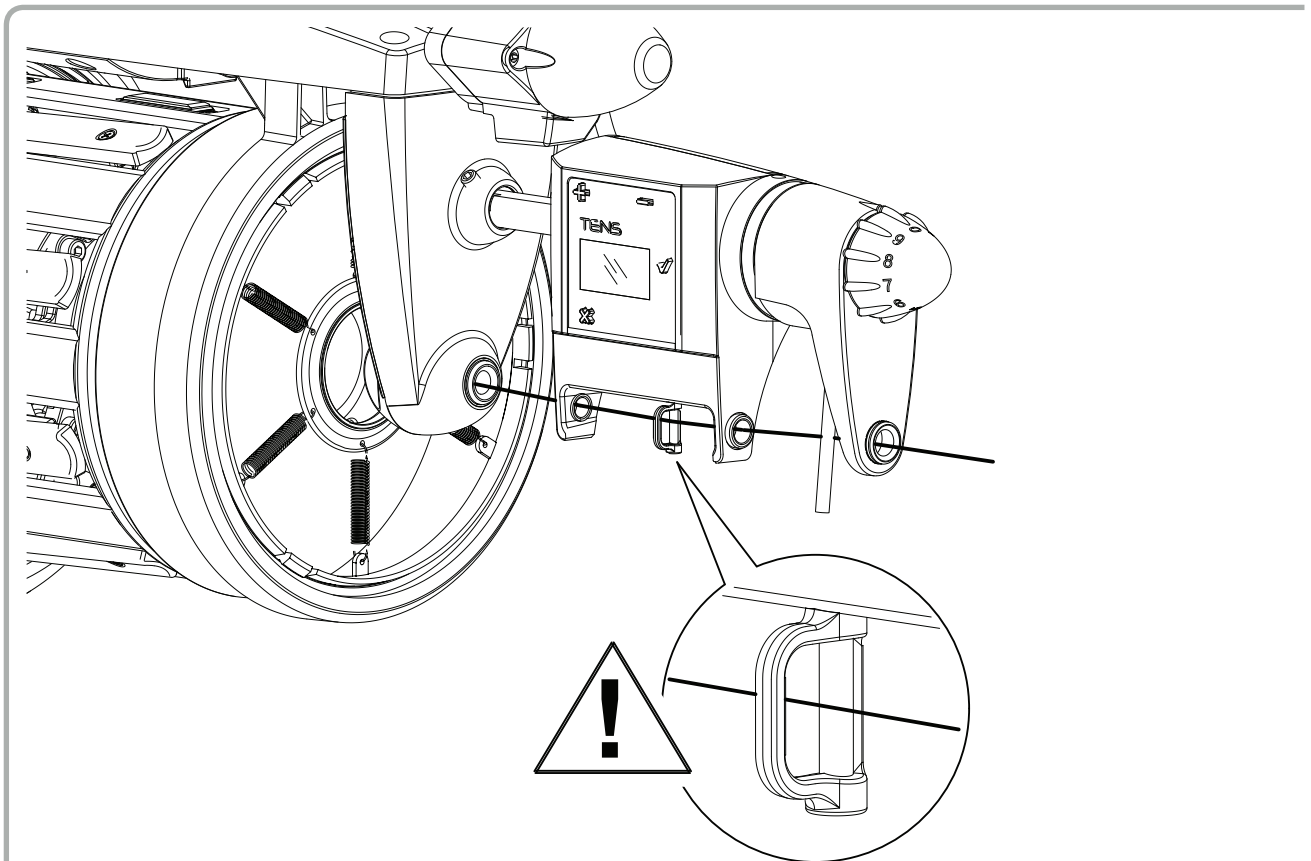

## 8.3 WHAT TO DO TO RUN THE MACHINE

At first installation the feeder is in manual mode (Light ON):

Start up the machine as with a traditional feeder. Instead of moving the front knob (to manually adjust the yarn tension), press + (to increase tension) or – (to decrease tension).

When by pulling the yarn by hand the tension seems correct, run the loom.

When the loom runs, after one hundred picks, and the tension is the desired one, pass to automatic mode.

Once the feeder will be in Automatic mode, the TENS light will turn OFF, the system will read the average tension on the yarn during the insertion and it will keep it constant. The average tension will be shown in the main screen of the display (desired tension).

### TENS HANDLING

The TENS must work in automatic mode.

If the loom is running, acting on + and – buttons it is possible to change the tension reference, the new tension reference will be adjusted immediately.

If the loom is standing, acting on + and – buttons it is possible to change the tension reference, the new tension reference will be adjusted when the loom will run again.

If the loom is running with the device in automatic mode:

- Press and release once + button to increase or – button to decrease. The tension increases or decreases by 1 cN at each press and release.

If the loom is standing with the device in automatic mode:

- Press and release once + button to increase or – button to decrease. The tension increases or decreases by one motor step at each press and release.

If an higher tension variation is desired, keep button pressed longer

# 8 - TENS AND SRAKE WITH DISPLAY FOR WEAVING MACHINES

Software from ELBR1736 (tens) and ELBR1836 (Srake)

## 8.4 PROCEDURA TO GO FROM MANUAL TO AUTOMATIC (and vice versa)

Enter the menu pressing Enter  $\sqrt{\quad}$ , then select Auto/Manual with minus ( - ) button.

```
1 Open Brake
2 Auto/Manual
5 Password
6 En rem. T.des
10 Offset
```

Press Enter  $\sqrt{\quad}$  again. The next screen will appear for some seconds, and the system goes to automatic.



Normally it is not necessary to bring the TENS back to manual mode. Once the TENS is in automatic mode, it has to stay in automatic mode.

It may be necessary to go back to manual mode only in case the offset of the load cell has to be performed (chapter 8.7), or to exclude the load cell if it does not work correctly.

If the system is in automatic mode and it is necessary to go back to manual mode, repeating the same procedure the screen which will appear for some seconds will be the next one, and the TENS will turn to manual mode.



**NOTE:** When the TENS is in manual mode, it is possible to adjust the brake acting on the + and - buttons.

# 8 - TENS AND SRAKE WITH DISPLAY FOR WEAVING MACHINES

Software from ELBR1736 (tens) and ELBR1836 (Srake)

## 8.5 TENSION ADJUSTING BY SETTING A DESIRED TENSION VALUE IN cN

In case the desired tension value on the yarn is known, it is possible to set this value in the system.

When the machine will be started up and the TENS will be turned into automatic mode, it will quickly move to adjust the pre set tension value.

This function must be set through the EN REM T DES parameter.

Press ENTER  $\sqrt$  to enter the Menu. Go to parameter EN REM T DES and press ENTER  $\sqrt$ .

Through buttons + and - it is possible to move from AUTOM T.DES. to REMOTE T.DES. and back.

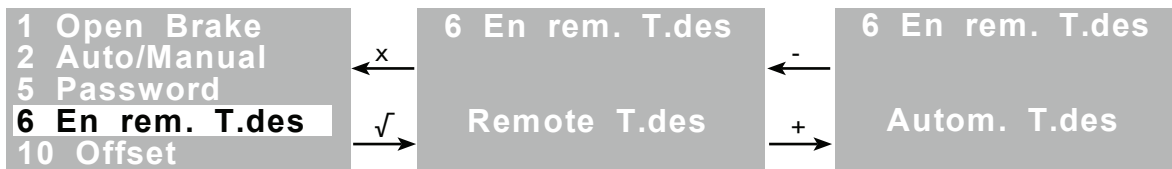

When AUTOM T.DES. is set, the tension value is set automatically through the procedure described in paragraph 8.3.

When REMOTE T.DES. is set, the tension value will have to be set through parameter REM.T.DES.

This parameter is accessible from the parameter list, or directly from the main screen keeping ENTER  $\sqrt$  pressed for 4 seconds.

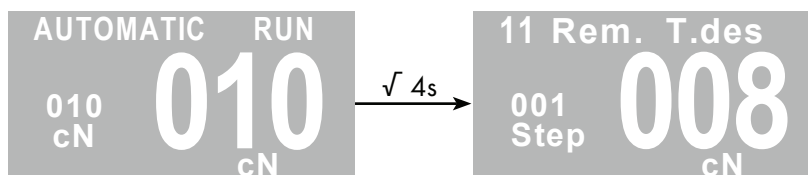

The number above the "Step" writing allows to move the desired tension of 1, 10 or 100 cN. Keeping pressed the + button, from 001 the value goes to 010. Repeating this operation the value goes to 100.

If "Step"=001, pressing one time + button the tension increases by 1 cN (pressin -, it decreases 1 cN)

If "Step"=010, pressing one time + button the tension increases by 10 cN (pressin -, it decreases 10 cN)

If "Step"=100, pressing one time + button the tension increases by 100 cN (pressin -, it decreases 100 cN)

The tension reference will change immediately and the TENS will follow the new reference.

## 8.6 BRAKE OPENING

When the loom is standing, enter the menu by pressing Enter  $\sqrt$

```
1 Open Brake
2 Auto/Manual
5 Password
6 En rem. T.des
10 Offset
```

Press ENTER  $\sqrt$  again. The brake will open. Exit by pressing X button, the brake will close.

If the brake is not closed and the loom starts, the feeder will send an alarm.

# 8 - TENS AND SRAKE WITH DISPLAY FOR WEAVING MACHINES

Software from ELBR1736 (tens) and ELBR1836 (Srake)

## 8.7 OFFSET

The Offset procedure allows to calibrate the zero point of the load cell.

Basically this procedure tells the load cell where 0 cN is.

It has already been performed in LGL, and it could require to be performed again only if the environmental condition change (for example during summer closure, or when the machine stands still for long time)

Every once in an while (for example when the machine is standing for a pattern change), it is advisable to check that the load cell returns 0 cN when the yarn is removed from the ceramic.

If the value is 0 (or close to 0, like 1 or 2), the load cell is working correctly and nothing must be made. On the contrary if the value is very different from 0, then the load cell needs a calibration, through the following procedure: TENS must be in MANUAL mode.

Enter the Menu by pressing ENTER √. Go to OFFSET e press ENTER √.

```
1 Open Brake
2 Auto/Manual
5 Password
6 En rem. T.des
10 Offset
```

```
10 Offset
380 cN 001 cN
```

Press ENTER √ a third time to execute the offset.

The TENS light will blink for some seconds, and the offset will be executed.

**NOTE:** If TENS is in automatic mode, the offset is not possible.

```
Offset impos.
380 cN 000 cN
```

From software version ELBR1740 and ELBR1840 Offset procedure changes, and you can leave TENS in automatic mode.

1. In case of ceramic sensor: Remove the yarn from the load cell.  
In case of ILC sensor: Do not remove the yarn from the load cell and go to point 2.
2. Enter the Menu by pressing ENTER √. Go to OFFSET e press ENTER √. The brake will open and the LED will blink once a second.

```
1 Open Brake
2 Auto/Manual
5 Password
6 En rem. T.des
10 Offset
```

```
10 Offset
380 cN 001 cN
```

3. Press ENTER √ to execute the offset. While the offset is being executed, the LED blinks three times per second, then it comes back to blink one time per second.
4. After 10 seconds the brake will close automatically and it will be ready to work. If you want to start earlier, press X to close the Brake.

## 8.8 ALARMS (only automatic mode)

When a Tens device goes in alarm, the light blinks and the machine stops. To reset the alarm, press "-".

The alarms that can appear on the display are:

- 1) **"Alarm state!"** = the TENS is in alarm..
- 2) **"Opening failure"** = Error during brake opening phase. Reset the alarm by pressing "-". By using "+" e "-", bring the brake back to its working position.
- 3) **"Cell failure"** = tension value read by the load cell not correct. This alarm can appear when a button is broken or when the buttons are pressed together. Reset the alarm by pressing "-".
- 4) **"Reg. timeout!"** = Unable to reach the pre set tension value. If the pre set reference (+/- 20%) is not reached within 200 picks, the alarm comes out.
- 5) **"Offset impos."** = Offset not possible because the brake is broken.
- 6) **"Yarn missing"** = There is no yarn on the load cell during insertion.

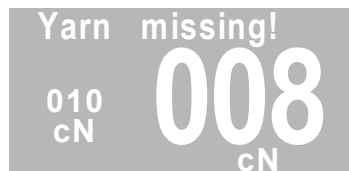

- 7) **"Low reference!"** = The yarn tension reference is too low (less than 3cN).

# 8 - TENS AND SRAKE WITH DISPLAY FOR WEAVING MACHINES

Software from ELBR1736 (tens) and ELBR1836 (Srake)

## 8.9 EXAMPLES

EXAMPLE1 : The loom is running, the feeder is working in automatic mode and the tension needs to be increased.

OPERATIONS: Press and release + button while the machine is running. The light blinks once and the tension increases by 1 cN. It is possible to press and release many times if the required tension increase must be bigger.

This works out also when the tension needs to be decreased, with – button.

EXAMPLE2: the feeder works normally with the brake in position 8 or 8.5 on the scale. This position is close to the complete closing position, which is around number 9.

The operator at this moment changes the yarn without touching the feeder. He starts to use a yarn whose characteristic cause a decrease of the average tension.

1. With a traditional equipment without tension sensor, if the brake is not moved, the yarn on the right side of the loom gets longer.
2. With TENS the feeder automatically moves the brake because the tension sensor feels a decrease of average tension. The yarn length on the right side stays constant.  
If in order to increase the tension the brake arrives at the edge of its stroke, it could give an alarm because the tension has not been reached (Reg. timeout).  
In this case the feeder brake must be replaced with a heavier one or the springs must be stronger.

**NOTE:** The Tens load cell with ceramic sensor can adjust tension up to 450 cN, while the ILC sensor can adjust up to 250cN.

## 8.10 LED MEANING

LED	MEANING
<b>ON</b>	Manual mode . The '+' and '-' buttons move the brake back and forth.
<b>OFF</b>	Automatic mode. With the loom running: the '+' and '-' buttons pressed once increase or decrease the tension reference by 1cN. With the loom standing: the '+' and '-' buttons, pressed once move the brake back and forth. The reference tension changes when the loom runs again.
<b>Slow blinking</b>	Brake opening or opened by the user (manual mode).
<b>3 fast blinks (one time)</b>	Offset procedure successfully performed.
<b>1 fast blinks when the button is released</b>	The command to increase/decreases the yarn tension by 1cN has been executed. (in automatic mode).
<b>2 fast blinks per second (repeated)</b>	Brake alarm status. (see alarms) If the alarm can be reset, it is possible to reset it by pressing "-".

# 9 - SPECIAL DEVICES

## 9.1 KNOT DETECTOR

This device prevents the knots that are on the thread to get into the fabric.

It is handled by the feeder and can possibly be used along with dedicated software packages supplied by the machine manufacturer (in this latter case, please consult the instruction manual of the weaving machine).

### INSTALLATION:

- 1) Switch off the yarn feeder by turning **0 - I** switch to **0**.



- 2) Turn off the power supply using the main switch on the textile machine.
- 3) Fix the knot detector in the back of the weft accumulator.
- 4) Insert the device cable connector in the relative position of the cover.

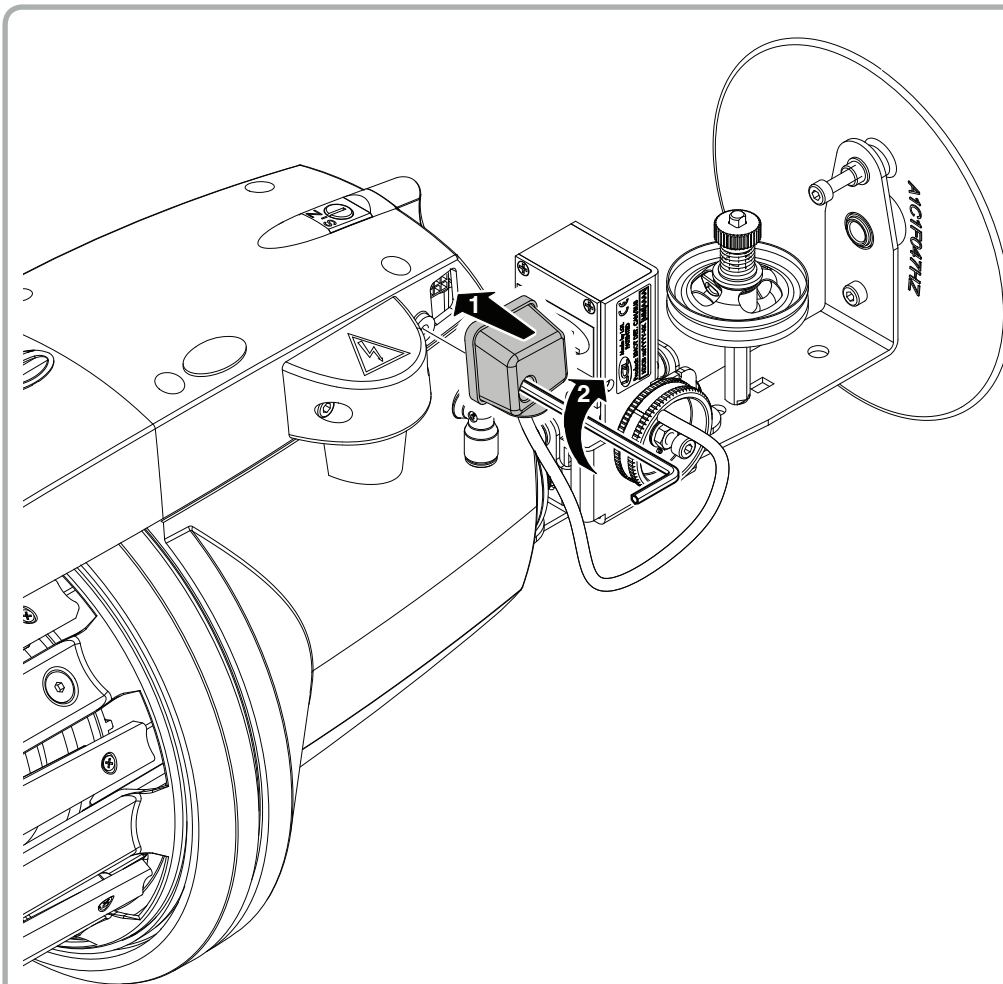

## 9 - SPECIAL DEVICES

### USE:

By following the graduated scale (**1**), act on the adjustment knob (**M**) so as to bring the shaped cylinder (**2**) to the thin blade (**3**). The adjustment shall be made so that the thread may freely run between the thin blade and the cylinder, whereas each knot shall touch the thin blade.

The thread-guides (**4**) can be adjusted in height by means of the related fastening knobs so as to allow the thread to easily flow within the device.

The knot detector operates both on traditional weaving machines and on those of the Can-Bus type.

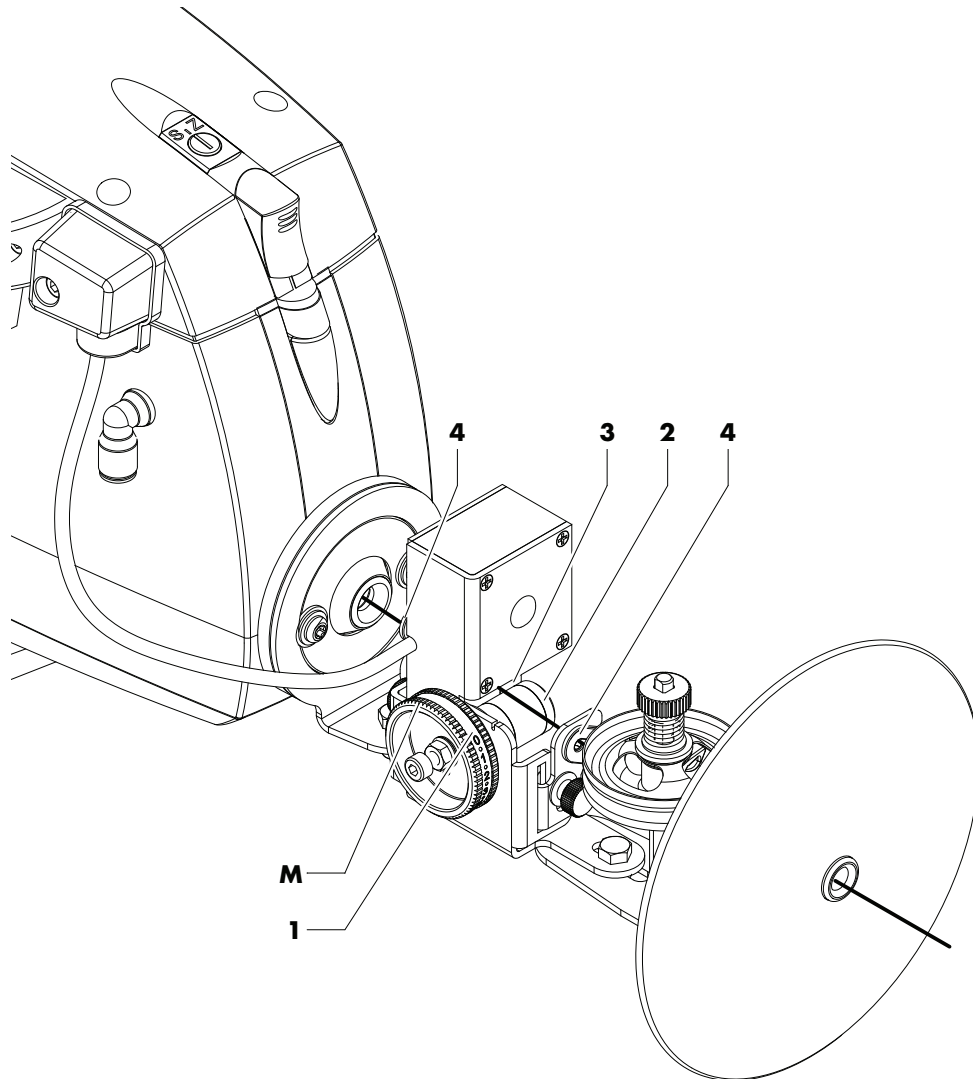

# 9 - SPECIAL DEVICES

## 9.2 MOTOR-DRIVEN OILING UNIT

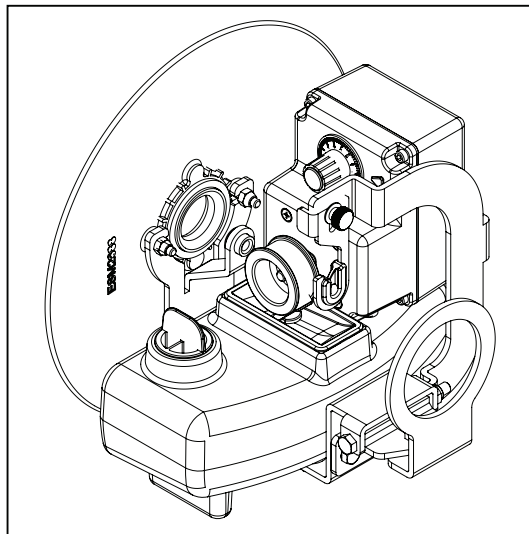

This device lubricates the yarn in a regular manner as a function of the yarn feeding speed. It is automatically started synchronized with the yarn feeding unit, which means that it does not turn when the yarn feeding unit is idle and it turns when the yarn feeding unit starts operating.

### INSTALLATION:

- 1) Switch off the yarn feeder by turning **0 - I** switch to **0**.



- 2) Turn off the power supply using the main switch on the textile machine.
- 3) Fix the oiling unit in the back of the weft accumulator.
- 4) Insert the device cable connector in the relative position of the cover.

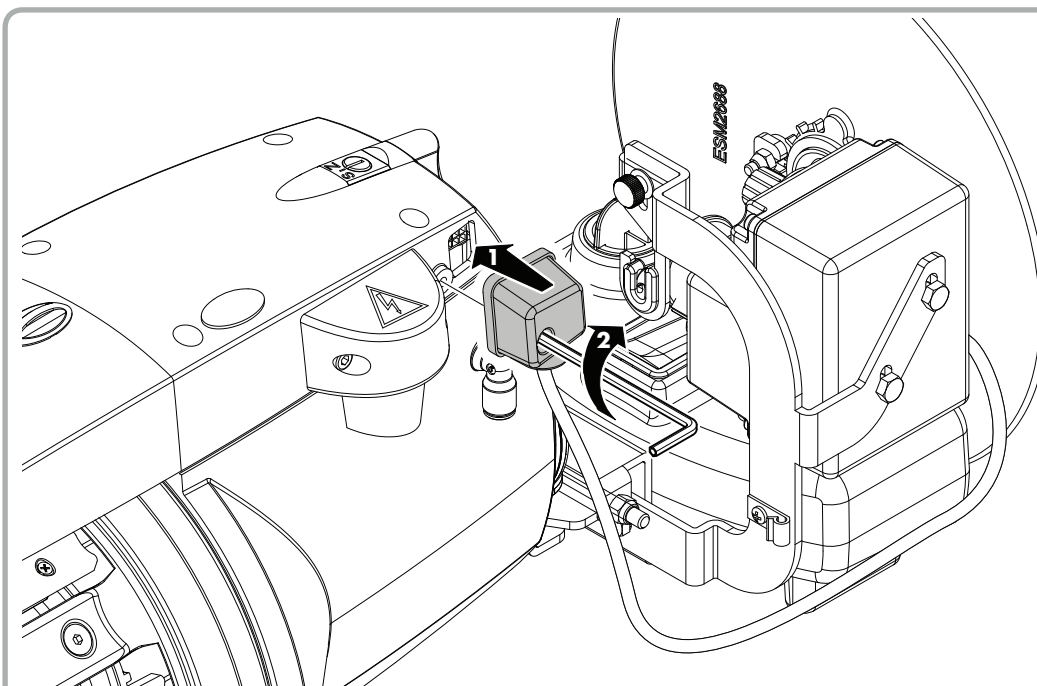

## 9 - SPECIAL DEVICES

### USE:

It is automatically started synchronized with the yarn feeding unit, which means that it does not turn when the feeding unit is idle and turns when the feeding unit starts operating. In order to adjust the amount of oil to apply to the yarn, operate the potentiometer **(3)** provided on the device. Open the special plug **(4)** to top up the oil level.

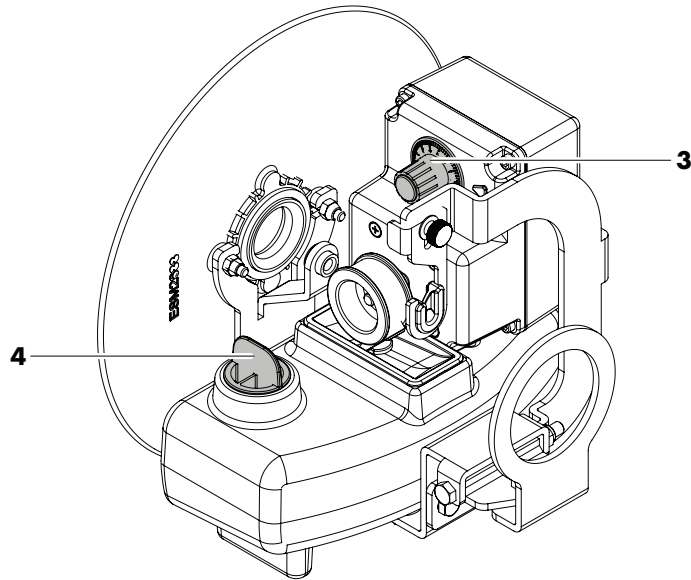

## 9 - SPECIAL DEVICES

### 9.3 MOTOR-DRIVEN WAXING UNIT

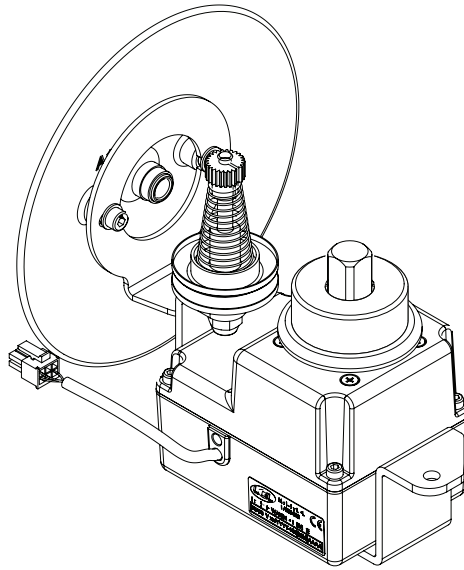

This device enables you to deliver wax to the thread in a regular manner as a function of the yarn feeding speed. It is automatically started synchronized with the yarn feeding unit, which means that it does not turn when the yarn feeding unit is idle and it turns when the yarn feeding unit is started.

#### INSTALLATION:

the waxing unit must be installed in the same way as the oiling unit. Please refer to the procedure provided above.

#### USE:

It is automatically started synchronized with the yarn feeding unit, which means that it does not turn when the yarn feeding unit is idle and it turns when the yarn feeding unit is started. Replace the wax disc when the latter is worn out.

# 10 - TROUBLE-SHOOTING

LED STATUS	PROBLEM	CHECK / REMEDY
Led off	The accumulator continues to turn, accumulating weft on the weft spool body.	<ul style="list-style-type: none"> <li>• Replace the main control board (see chapter 5.2).</li> </ul>
Led on	The accumulator continues to turn, accumulating weft on the weft spool body.	<ul style="list-style-type: none"> <li>• If working with fine weft yarns, increase the input tension and/or decrease the coil separation.</li> <li>• Replace the main control board (see chapter 5.2).</li> </ul>
Led on	The motor fails to turn when the accumulator is switched on.	<ul style="list-style-type: none"> <li>• Replace the main control board (see chapter 5.2).</li> </ul>
Led flashes 3 times a second	The motor fails to turn when the accumulator is switched on.	<ul style="list-style-type: none"> <li>• Check for faulty fuses in the power supply box.</li> <li>• Check the fuse on the main control board: if blown, replace the main control board (see chapter 5.2).</li> </ul>
Led remains on or off (despite using the ON/OFF switch)	The motor fails to turn when the accumulator is switched on.	<ul style="list-style-type: none"> <li>• Disconnect the accumulator cable from the power supply box and then reconnect after a few seconds. If the problem persists, replace the main control board (see chapter 5.2).</li> </ul>
Led remains on (despite using the ON/OFF switch)	The accumulator fails to work.	<ul style="list-style-type: none"> <li>• Check the fuse in the power supply box.</li> <li>• Check that the power supply box is switched on.</li> <li>• Replace the main control board (see chapter 5.2).</li> </ul>
Led flashes 3 times a second (accumulator works normally)	The DC power supply has dipped below the minimum threshold.	<ul style="list-style-type: none"> <li>• Check that the three input phases of the transformer inside the power supply box are connected to the right terminals.</li> <li>• Check for faulty fuses in the power supply box. If none of the fuses are blown, replace the main control board (see chapter 5.2).</li> </ul>
Led flashes 3 times a second	Main control board overheats.	<ul style="list-style-type: none"> <li>• Manually turn the flywheel and check that the motor shaft turns freely.</li> <li>• Wait for the accumulator to cool down. If the problem persists, replace the main control board (see chapter 5.2).</li> </ul> <p><b>N.B.: When weft insertion conditions are irregular, it is quite normal for the accumulator to overheat without this affecting its performance.</b></p> <p><b>The microprocessor automatically cuts the supply to the motor if the temperature of the last power stage reaches 100°C: the accumulator will only start again when the temperature drops to an acceptable level.</b></p>
Led on for 15 seconds then flashes 3 times a second	The accumulator has been unable to wind the spare weft coils within the space of 15 seconds.	<ul style="list-style-type: none"> <li>• Try to load the spare wefts again, holding the thread near the weft spool body to help it.</li> <li>• Check for faulty fuses in the power supply box.</li> <li>• Manually turn the flywheel and check that the motor shaft turns freely.</li> </ul>

# 10 - TROUBLE-SHOOTING

LED STATUS	PROBLEM	CHECK / REMEDY
Led flashes 7 times a second	The feeder operates regularly.	<ul style="list-style-type: none"> <li>• Make sure that switch S - 0 - Z is not in the middle position 0 (zero), but either at S or Z to suit the direction of rotation.</li> <li><b>N.B. In cases when the "Loom Stop" position is enabled on the loom, the intermediate position 0 (zero) of the S - 0 - Z switch allows for switching off the weft accumulator that is not using without turning off the loom.</b></li> </ul>
Led flashes once a second	Broken weft at input.	<ul style="list-style-type: none"> <li>• Switch off the accumulator, rethread and then switch back on.</li> </ul>
Led on	<p>The accumulator gradually tends to lose weft from the weft spool body.</p> <p>The accumulator fails to work at a constant speed when constant weft insertion is required.</p>	<ul style="list-style-type: none"> <li>• Replace the main control board (see chapter 5.2).</li> </ul>
Led flashes once a second	The accumulator immediately goes into broken weft alarm mode when the loom starts, even if this is not the case.	<ul style="list-style-type: none"> <li>• Clean the input sensor (see chapter 1.5).</li> <li>• Replace the main control board (see chapter 5.2).</li> </ul>

**N.B.:** After replacing the board, follow the procedure described in the chapter 5.3 to calibrate the motor and the photocells and adjust the position of the flywheel ceramic for pneumatic threading.

**N.B.:** as regards operation of the Can-Bus protocol, please refer to the instruction manual issued by the manufacturer of the weaving machine.

# 11 - SCRAPPING

The identification plates and relevant documents must be destroyed or cancelled if the machine is to be scrapped. If the machine is to be scrapped by third parties, only use authorised disposal centres for the scrapping/recovery of the consequent materials.

If the machine is to be scrapped directly by the user, it is important that the materials are split by type and then sent to authorised centres for proper disposal of each category.

Separate all metal parts, the electric motor, rubber parts and synthetic materials for recycling. The machine must be scrapped in full compliance with prevailing law in the country of use. These requirements cannot be foreseen here: the exclusive responsibility for compliance with these lies with the last owner of the machine or his appointed representative.

**L.G.L. Electronics** cannot be held liable for any damage or injury arising from the reuse of individual machine parts for functions or assembly situations other than the original ones for which the machine was intended.

# L.G.L. ELECTRONICS S.p.A.

*Sede amministrativa, legale e stabilimento: Via Foscolo 156, - 24024 Gandino (BG) - Italy  
Tel. (Int. + 39) 35 733408 Fax (Int. + 39) 35 733146*

---

—ITALIANO—

## DICHIARAZIONE DI CONFORMITÀ CE

La macchina è un alimentatore di trama per telai di tessitura a pinza o proiettile.

Produttore: **L.G.L. Electronics**  
Modello: **ECOPROGRESS**



La macchina è conforme ai requisiti essenziali delle direttive 2006/42/CE, 2014/35/UE, 2014/30/UE.

— ENGLISH —

## CE CONFORMITY DECLARATION

This machine is a weft accumulator, suitable for rapier and projectile weaving machines.

Manufacturer: **L.G.L. Electronics**  
Model: **ECOPROGRESS**



The machine is in compliance with the main requirements of directives 2006/42/CE, 2014/35/UE, 2014/30/UE.

— FRANÇAISE —

## DECLARATION DE CONFORMITE CE

L'appareil est un délivreur de trame pour métiers à tisser à pinces ou à projectile.

Producteur: **L.G.L. Electronics**  
Model: **ECOPROGRESS**



La machine est conforme aux conditions requises essentielles des directives 2006/42/CE, 2014/35/UE, 2014/30/UE.

— DEUTSCH —

## CE ÜBEREINSTIMMUNGS ANGABE

Die Maschine ist ein Vorspulgerät für Greifer - oder Projektil - webmaschinen.

Hersteller: **L.G.L. Electronics**  
Typ: **ECOPROGRESS**



Die Maschine entspricht der wesentlichen Anforderungen der Richtlinien 2006/42/CE, 2014/35/UE, 2014/30/UE.

— ESPAÑOL —

## DECLARACIÓN DE CONFORMIDAD CE

La máquina es un alimentador de trama para máquinas para tejer a pinzas o proyectil.

Productor: **L.G.L. Electronics**  
Modelo: **ECOPROGRESS**



La máquina está en conformidad con los requisitos esenciales de las directivas 2006/42/CE, 2014/35/UE, 2014/30/UE.

— PORTOGUES —

## DECLARAÇÃO DE CONFORMIDADE CE

A máquina é um alimentador de trama para teares de tecelagem a pinzas ou a projectil.

Productor: **L.G.L. Electronics**  
Modelo: **ECOPROGRESS**



A máquina está em conformidade com os requisitos essenciais das directivas 2006/42/CE, 2014/35/UE, 2014/30/UE.

— NEDERLANDS —

### VERKLARING VAN CE OVEREENSTEMMING

Deze machine is een inslaggaren voorafwikkelaar voor grijper-en projectielweefmachines.

Merk: **L.G.L. Electronics**  
Type: **ECOPROGRESS**



De machine voldoet aan de essentiële vereisten van de richtlijnen 2006/42/CE, 2014/35/UE, 2014/30/UE.

— ΕΛΛΗΝΙΚΑ —

### ΔΗΛΩΣΗ ΣΥΜΜΟΡΦΩΣΗΣ CE

Το μηχάνημα είναι ένας τροφοδότης υφαδιού που δουλεύει με όλους τους τύπους αργαλειού.

Μάρκα: **L.G.L. Electronics**  
Τύπος: **ECOPROGRESS**



Η μηχανή πληρεί τις βασικές προϋποθέσεις που ορίζονται από τις οδηγίες 2006/42/CE, 2014/35/UE, 2014/30/UE.

— SVENSKA —

### CE ÖVERENSSTÄMMELSEDEKLARATION

Maskinen är en väffsmatare för band - eller skyttelvävstolar.

Märke: **L.G.L. Electronics**  
Typ: **ECOPROGRESS**



Maskinen överensstämmer med de grundläggande kraven enligt EU-direktiven 2006/42/CE, 2014/35/UE, 2014/30/UE.

— SUOMEKSI —

### CE VASTAAVUUSTODISTUS

Kone on nauha-tai sukkulakudontalaitteen kuteen syöttölaite.

Merkki: **L.G.L. Electronics**  
Tyyppi: **ECOPROGRESS**



Kone on direktiivien 2006/42/CE, 2014/35/UE, 2014/30/UE olennaisten vaatimusten mukainen.

— DANSK —

### CE ÖVERENSSTEMMELSEERKLÄRING

Maskinen er en skudtrådsføder til bånd- eller skyttelvæve.

Mærke: **L.G.L. Electronics**  
Type: **ECOPROGRESS**



Maskinen opfylder de grundlæggende krav i EU-direktiverne 2006/42/CE, 2014/35/UE, 2014/30/UE.

*Gandino, 01/12/2022*

Authorized to compile the technical file  
// Direttore Generale: Ing. Zenoni Pietro



**L.G.L. ELECTRONICS S.P.A**

Via Ugo Foscolo 156 – 24024 Gandino (BG) – Italy  
Tel. 0039 035 733408 – Fax 0039 035 733146 – Mail: lgl@lgl.it

---

**DECLARATION OF CONFORMITY UKCA**

The machine is a weft accumulator.

Manufacturer: **L.G.L Electronics S.p.A** **UK**  
Model: **ECOPROGRESS** **CA**

**L.G.L Electronics S.p.A** DECLARE

under its responsibility that the ECOPROGRESS are designed, manufactured and commercialized in compliance with the following UKCA Standards:

- The Electrical Equipment (Safety) Regulations 2016 – UK SI 2016 No. 1101
- Electromagnetic Compatibility Regulations 2016 – UK SI 2016 No. 1091
- Supply of Machinery (Safety) Regulations 2008 – UK SI 2008 No. 1597

Gandino (BG), 19/09/2022

**CEO: Pietro Zenoni**

A handwritten signature in black ink, appearing to read 'Pietro Zenoni', is written below the printed name.



L.G.L. Electronics S.p.A. reserve the right to alter in any moment one or more specifications of his machines for any technical or commercial reason without prior notice and without any obligation to supply these modifications to the machines, already installed.

T +39 035 733 408 **L.G.L. Electronics S.p.A.**  
F +39 035 733 146 Via Ugo Foscolo, 156  
lgj@lgl.it 24024 Gandino (BG)  
www.lgl.it Italy